

Instruction, Use and Maintenance Manual



PNEUMATIC ACTUATORS

MACH83

MACH98

MACH156

Bardiani Valvole S.p.A.

via G. di Vittorio, 50/52 - 43045 Fornovo di Taro (PR) - Italy

tel. +39 0525 - Fax 0525 3408

bardiani@bardiani.com - www.bardiani.com

MANUAL REVISION	DATE

INDEX

1	Safety, Warning and Mandatory Signs	5
1.1	Operator training	8
2	Safety	9
2.1	General safety warnings	9
3	Technical data	9
4	Checking / Unpacking / Lifting	10
5	Installation	11
6	Operation	12
7	Troubleshooting	12
8	Cleaning	13
9	Disposal	13
10	Maintenance	14
10.1	General maintenance	14
10.2	Scheduled maintenance	14
10.3	Useful TOOLS for Disassembly/Assembly	15
10.4	Pneumatic actuator MACH83-MACH98	16
10.5	Disassembly of the MACH83-MACH98	18
10.6	Assembly of the MACH83-MACH98	22
10.7	Pneumatic actuator MACH156	31
10.8	Disassembly of the MACH156	33
10.9	Assembly of the MACH156	39
11	Annexes	49
12	2D diagram cylinder MACH 83-MACH98	51
13	2D diagram cylinder MACH156	52
14	Warranty	53
15	Recommendations	54

INTRODUCTION

This "Instruction, Use and Maintenance Manual" has been prepared to provide guidance and recommendations to assist qualified skilled technicians in the understanding, running and maintenance of the Products supplied.

It forms an integral part of the Products supplied and must be read prior to any installation, operation and/or maintenance of all types of valve provided.

This manual must be saved for future reference and be kept readily available at the unit.

With regards to the use of valve compliant with EU Directive 2014/34/UE (ATEX), consultation of a specific manual is mandatory.

The essential characteristics of all types of valve described herein being consistent, the Manufacturer reserves the right to alter and or complement and or update at any time and with no obligation to notify so in writing, the data and or information relevant to the use of the valve described in this "Instruction, Use and Maintenance Manual".







A constantly updated version of this "Instruction, Use and Maintenance Manual" is available at the Manufacturer's website www.bardianivalvole.it.







Under no circumstance shall the Manufacturer be held liable for consequences resulting from failure and or improper use of the instructions contained in this Manual and relating to the installation, operating, maintenance and storage of the products.





All rights reserved.







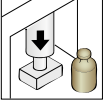
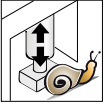

Full or part reproduction, transfer and or recording of any part of this "Instruction, Use and Maintenance Manual" by all means, whether it be electronic, on hard copy, mechanical or any other means or recording or reuse is strictly prohibited without the prior written consent of the Manufacturer and for any use other than that of the Buyer.

1 Safety, Warning and Mandatory Signs

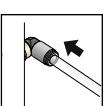
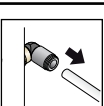
WARNING SIGNS		
Pictogram	Description	Notes
	CAUTION General	This tells the person in question that the operation described involves (when not performed in accordance with the relative safety regulations) the risk of personal injury.
	CAUTION Hand crushing	Exercise caution in executing the procedure Hand crushing hazard
	CAUTION Heavy loads	Exercise caution in executing the procedure Heavy suspended loads.
	CAUTION Severe burns	Heat emission hazard Very hot surface, risk of severe burns
	CAUTION Risk of explosions	Take Care, risk of explosions
	WARNING Spring Under load	When dismantling, pay attention to spring under load

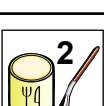
MANDATORY SIGNS (FOR THE OPERATOR IN CHARGE OF MECHANICAL MAINTENANCE AND FOR THE OPERATOR IN CHARGE OF ASSEMBLY/DISASSEMBLY)		
Pictogram	Description	Notes
	OBLIGATION General	Special instructions must be followed to avoid injury to persons.
	PROTECTIVE GLOVES	Protective gloves must be available for handling objects which could cause hand injuries or when there is the possibility of coming into contact with harmful substances..
	HARD HAT	Hard hats must be available when hoisting heavy parts.
	FOOTWEAR	Use safety footwear to protect against injuries caused by falling objects during maintenance operations (particularly when dismantling parts).
	SUITABLE CLOTHING	Suitable clothing such as overalls. It is strictly prohibited to wear clothes with large flapping sleeves and/or other loose items which could easily get caught up in machine parts.
	SAFETY GLASSES	Protective glasses must be available when there is the possibility of contact which harmful substances which could cause eye injuries.

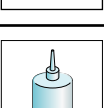
Operating signs		
Pictogram	Description	Notes
	SKILLED PERSONNEL	Disassembly/Assembly and maintenance operations must be carried out by expert technicians only.
	NOTE	Follow the indicated note with care
	ENVIRONMENTAL NOTE	Follow the regulations in force in the country of used governing waste disposal.
	CLAMP	Use of a clamp
	CLAMP WITH SOFT JAWS	Use of a clamp with jaws made from soft material

OPERATING SIGNS		
Pictogram	Description	Notes
	PRESS	Use of a press
	PRESS	Use of a press Gradual movement.
	ELECTRICAL CONNECTION	Electrical connection to the control unit (consult the relative instruction manual).
	ELECTRICAL DISCONNECTION	Electrical disconnection from the control unit (consult the relative instruction manual).
	PNEUMATIC CONNECTION	Connection of the air to the actuator.
	PNEUMATIC DISCONNECTION	Disconnection of the air to the actuator.
	APPLICATION OF NSF-H1 GREASE	Use CIP-FILM grease or similar
	APPLICATION OF NSF-H1 GREASE	Use FOODLUBE Multi-paste grease or similar
	APPLICATION OF NOT NSF-H1 GREASE	Use AGIP GREASE MU EP 2 SE or similar
	THREADLOCK APPLICATION	Use SPEED BOND M500 threadlock or similar
	OPTIONAL	

1.1 Operator training



All persons who have to work on the valve must be qualified to carry out the relative maintenance tasks. They must be informed as to the possible hazards involved and must observe all the safety instructions set out in this manual. Allow expert personnel only to work on the electrical components.

2 Safety

2.1 General safety warnings



Intended use

The MACH series pneumatic actuators are intended for installation on ZVF and ZVS valves produced by Bardiani Valvole s.p.a..

Prohibited use

Valves must not be used:

- for any operations different to those described under the heading "Intended Use",
- Caution: before moving the double-acting actuators, connect both pneumatic connections to the solenoid valves to limit the switching speed and avoid irreversible damage.



**SPRING UNDER LOAD CAN CAUSE INJURY.
OPENING THE ACTUATOR IS A POTENTIALLY DANGEROUS
OPERATION FOR HEALTH AND LIFE.**



**BARDIANI VALVOLE S.p.A. declines all liability
for installation, use or maintenance which fails to comply with
the indications provided in this manual!**

3 Technical data

PNEUMATIC ACTUATOR DATA	
Connectors	1/8" BSP
Tube dimension	6 mm external diameter, 4mm internal diameter
Air pressure	From 6 bar to 8 bar
Air quality	Class 2,4,3 ISO8573-I
Material	AISI 304L[1.4307]
Gaskets material	NBR
Noise levels	76 dB
Electrical supply	See Giotto Top

In the event of any doubt, please contact Bardiani Valvole S.p.A.

4 Checking / Unpacking / Lifting

1. CHECK:

- Please check that the actuator shows no signs of damage caused during transport and that it corresponds with the order;
- Remove the pneumatic actuator from the wooden case.
- Lift the pneumatic actuator

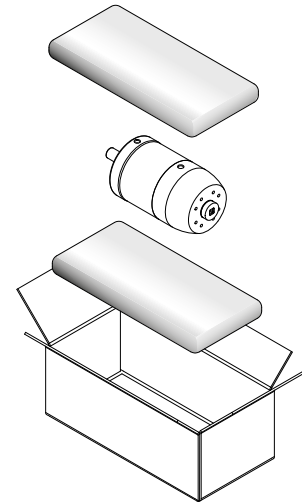

2. UNPACKING:

The valve packaging is made up of cardboard, wood and plastic. The valve is mainly made up of metal materials. The gaskets are usually made from elastomers. Disposal must be in compliance with local legislation.

VERSION / MODEL	WEIGHT
Mach83	3,9 Kg
Mach 98	4,3 Kg
Mach 156	18.5 Kg



3. VALVE LIFTING:

Be mindful of the type of valve you are handling: based on the size there are different lifting procedures.



For manual handling of the load, refer to the regulations in force in the country of destination.



Only qualified technical personnel must carry out handling operations of the equipment.



CAUTION!

Before lifting the valve, make sure there are no disassembled or separate valve parts which could fall off

causing injury to persons and damage to the valve.

5 Installation



1. ELECTRICAL AND PNEUMATIC ENERGY SUPPLY

- Use expert personnel for installation/disinstallation operations;
- Check that air pressure and quality are correct (see "Technical Data");

A = Connect the compressed air supply hose to the Single Acting and Double Acting actuators

B = Connect the compressed air supply hose to the Double Acting actuators

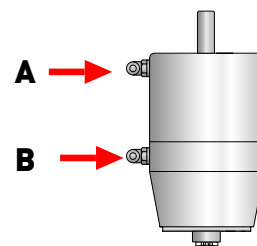
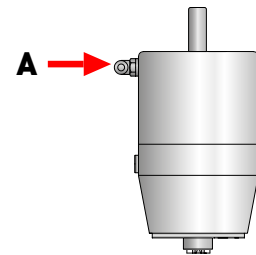

CAUTION!

Bardiani Valvole S.p.A. declines all liability for any damage to things and/or injuries to persons caused by any failure to correctly follow the installation procedures.

6 Operation



1. PNEUMATIC ACTUATOR INSPECTION BEFORE OPERATION:

- Supply air to the actuator;
- Check that the valve works correctly and accurately (do not use in the double acting actuator).

A = Actuator movement counterclockwise (standard version)

B = Actuator movement clockwise (standard version)

In single-acting valves there is only the connection defined as A, the clockwise rotation of the actuator is due to the action of a spring that is always under load.

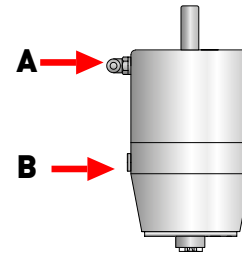

7 Troubleshooting



TROUBLE	POSSIBLE CAUSE	POSSIBLE SOLUTION
Difficulty in performing the rotational movement	Air leaks due to wear of the gaskets	Replace the gasket
	Incorrect positioning of the actuator	Install the actuator correctly
	Impurities in the actuator	Inspection and maintenance of the actuator
Inability to perform the rotational movement	Too high resisting torque	Check the correct functioning of the valve on which the actuator is applied. If necessary, carry out maintenance.
	Lack of pneumatic power supply	Check the correct pneumatic connection and the actual presence of air at the correct pressure
	Spring breakage or damage (single acting actuators)	Perform maintenance
	Cam breakage or damage	Perform maintenance

8 Cleaning



1. VALVE CLEANING WITH DETERGENTS:

The system in which the valve is installed must be cleaned by expert personnel in observance of the following:

- Stick to the indicated concentrations of detergents;
- Observe the instructions provided by the detergent manufacturer.
- Always wear protective safety glasses and gloves.



IMPORTANT!

- Accurately dose detergents to avoid excessive concentration;
- Always rinse thoroughly with clean water after washing.
- Check compatibility of valve materials.

9 Disposal



At the end of its service life, the device must be recycled in accordance with the legislation in force in the country of valve use.

Any hazardous residues must be taken into consideration and adequately handled.

The valve is made of AISI 316L and AISI 304 stainless steel, NBR (gaskets), plastic (control unit) and electrical components (terminal boards, solenoid valves, sensors).

Adhere to the following steps before disconnecting the valve and refer to the heading "General Maintenance".

- make sure the line on which the valve is installed in is not in use
- empty the line on which the valve is installed and clean if necessary
- disconnect the air supply if it is not required during dismantling
- disconnect the valve from the power supply
- remove the valve from the system
- move the valve in observance of the rules set out in the heading "Lifting"
- to dismantle the valve, refer to the heading "Disassembly"

10 Maintenance

10.1 General maintenance



1. MAINTENANCE PRECAUTIONS

Maintenance operations must be carried out by expert technicians only.



CAUTION!

Maintenance operations must be carried out with the line stopped and all utilities (electricity, compressed air) disconnected.



2. CLEANING AWAY DEPOSITS:

- Thoroughly wash and clean all the valve parts before disassembly;
- Pay attention to any possible detergent or other aggressive fluid deposits (see "Cleaning");
- Always use protective safety glasses and gloves when required.







3. REPLACEMENT OF WORN VALVE PARTS:

Always use original spare parts

10.2 Scheduled maintenance

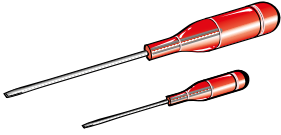
SCHEDULED MAINTENANCE	ACTUATOR GASKETS
In the event of leaks	Replace in the event of leaks
Periodical	Check correct operation and that there are no leaks
	Record the actions carried out

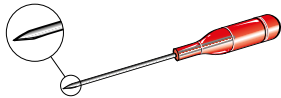
10.3 Useful TOOLS for Disassembly/Assembly

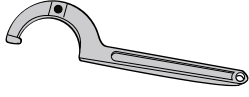
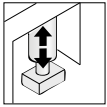
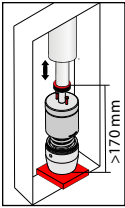
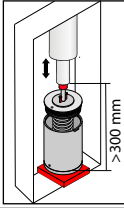
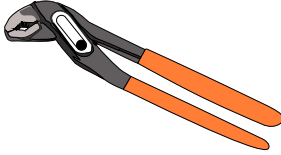
TOOLS	MACH83 MACH 98	MACH156
		
		
	3 - 4 - 8	
	99ST 35-50	
		
		



During the maintenance phases, be careful and secure the valve so that it cannot fall off the maintenance bench.

10.4 Pneumatic actuator MACH83-MACH98

NO.	DESCRIPTION
4	Sealing ring
9	Actuator
11	Pin
13	Piston
16	Sealing ring
19	Sealing ring
20	Lock wire
23	Upper shaft
31	Spring
40	Plug
41	Pin
77	Nut
98	Insert
150	Threaded plug
158	Pipe
178	Sealing ring
179	Grub screw
282	Guide bush

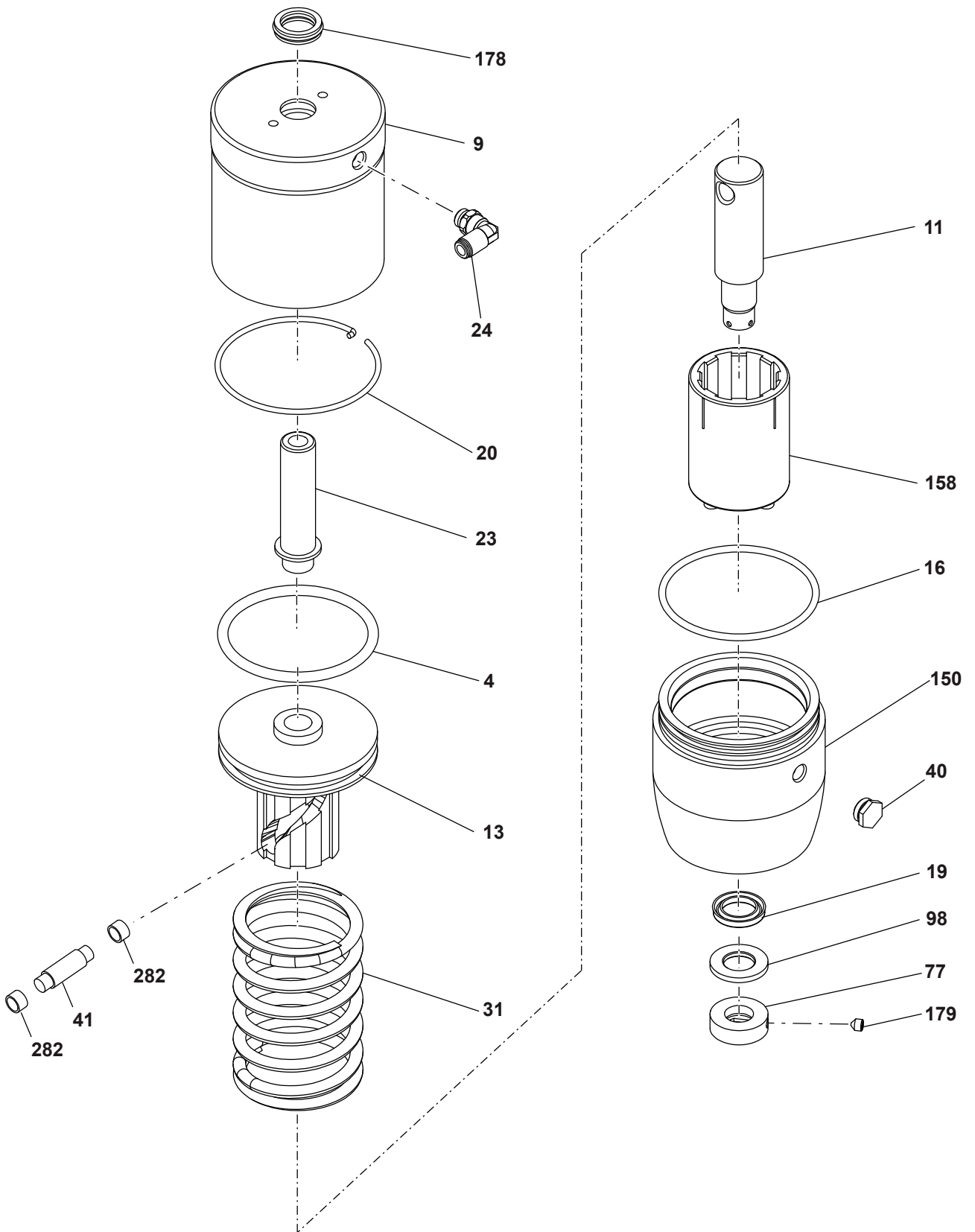

10.5 Disassembly of the MACH83-MACH98

1

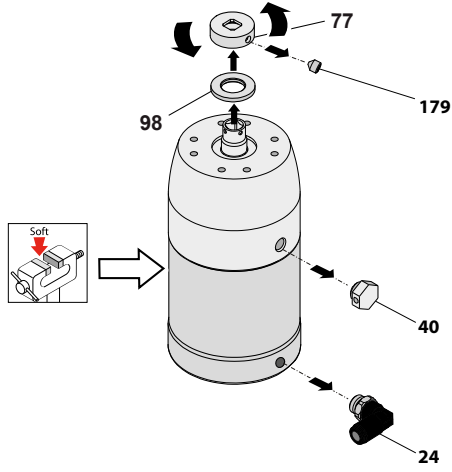

2

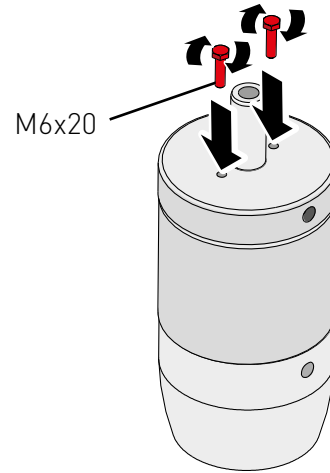

3

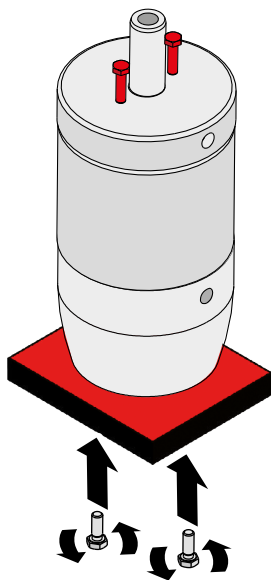

4

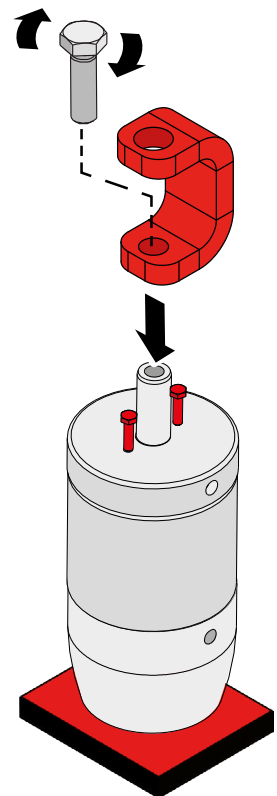

5

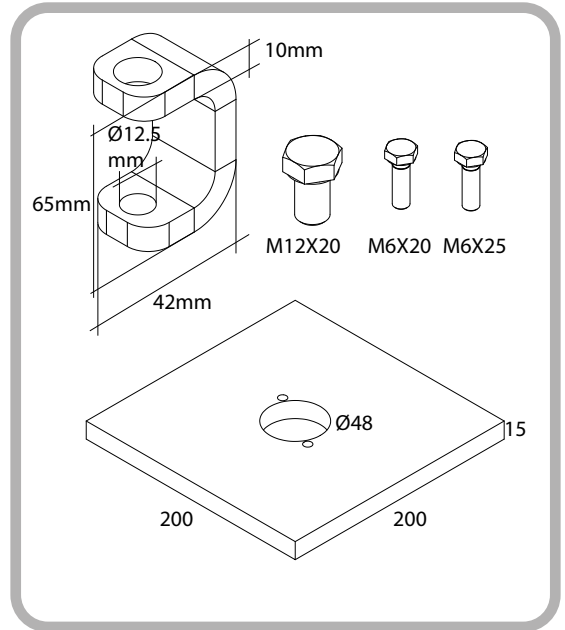
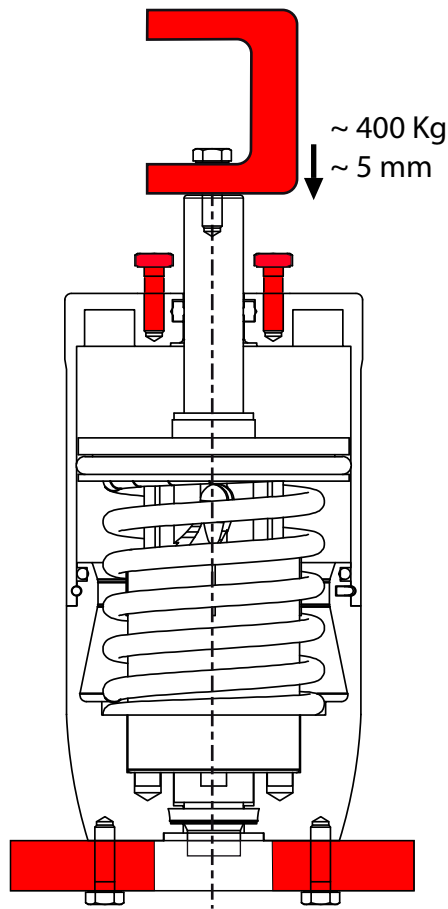
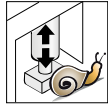

THESE ITEMS ARE NOT PROVIDED BY BARDIANI VALVOLE S.P.A.

6

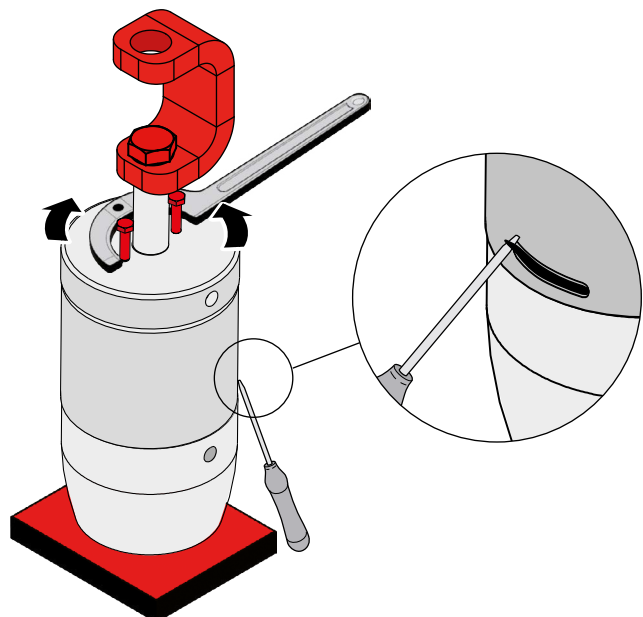
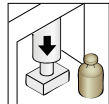

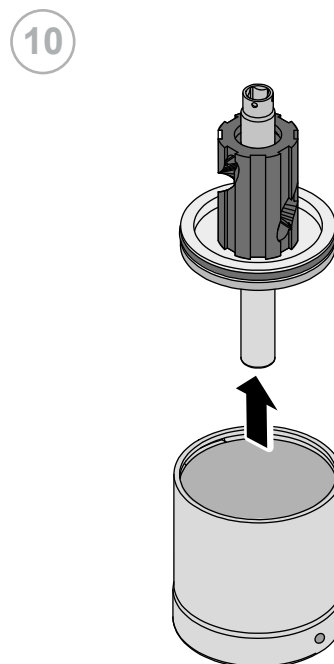
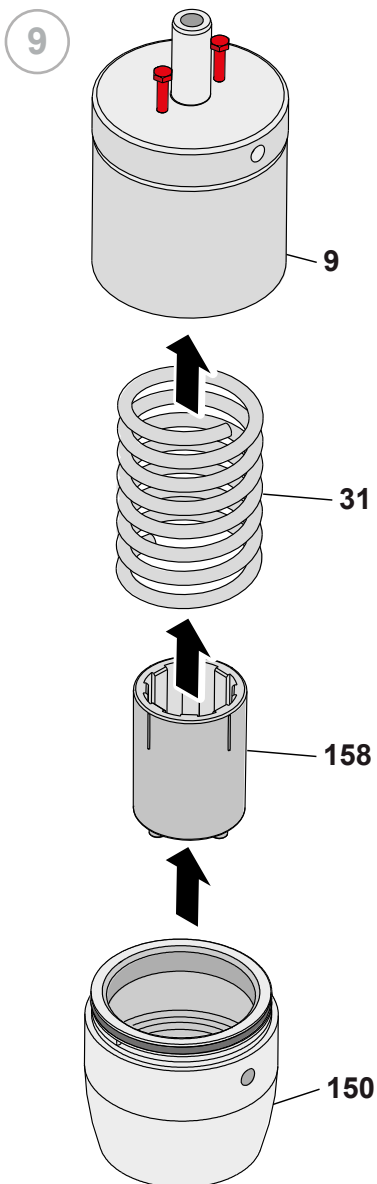
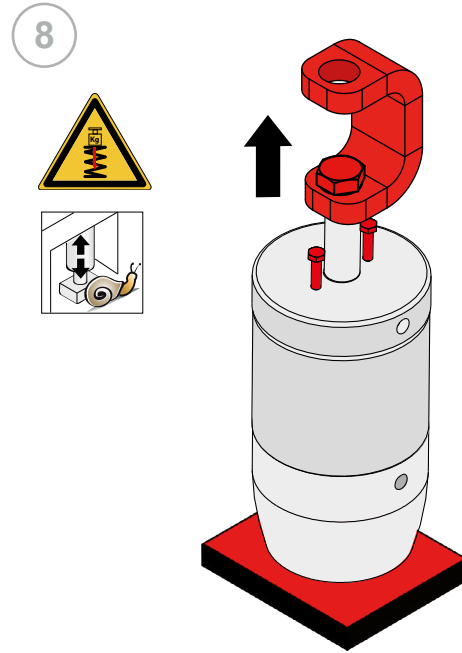
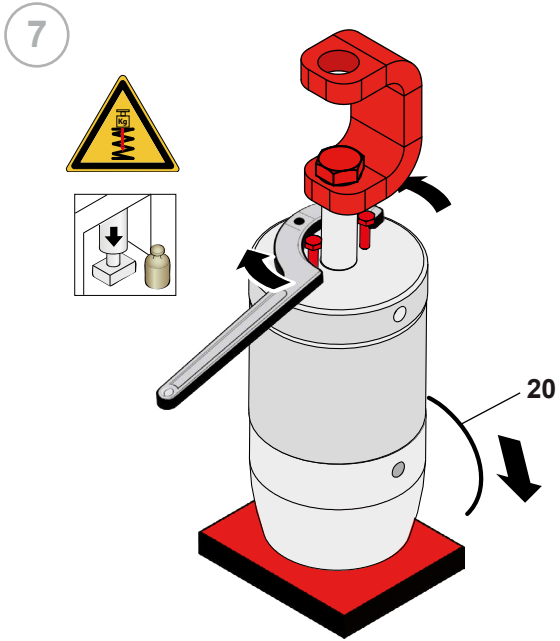

11

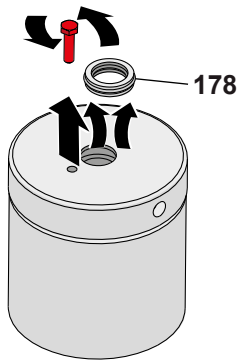

12

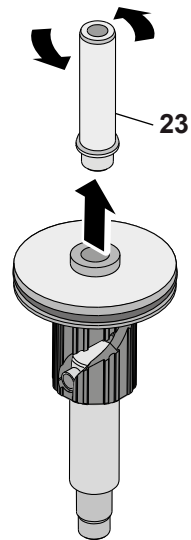

13

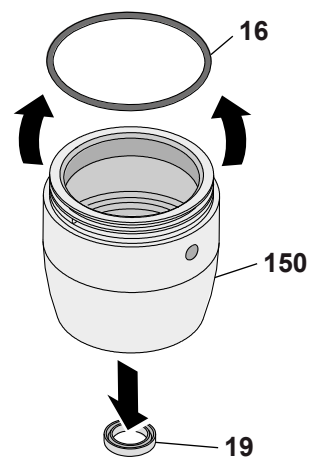

10.6 Assembly of the MACH83-MACH98

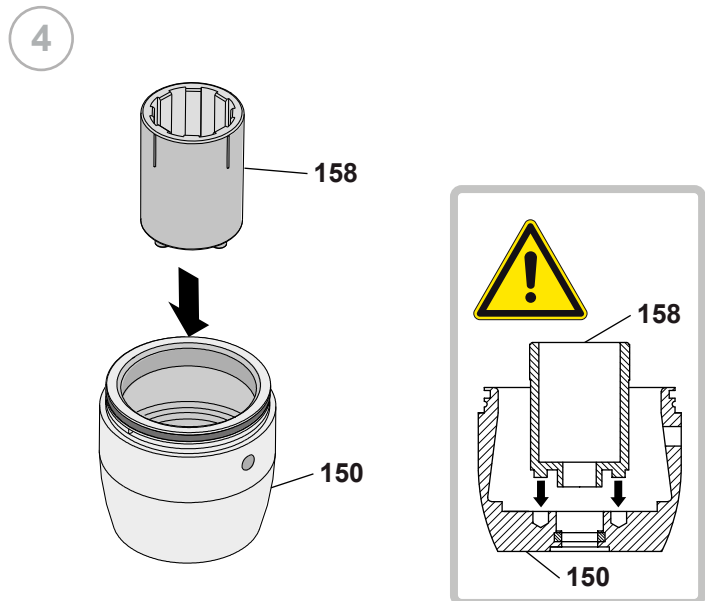
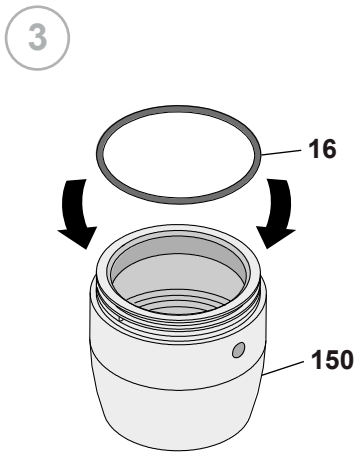
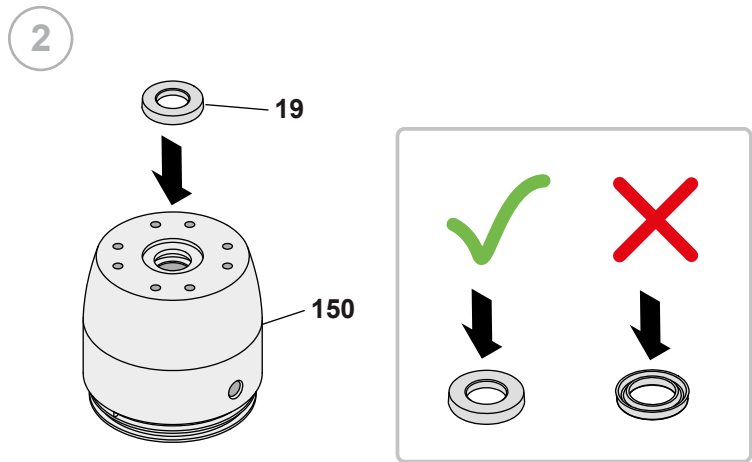
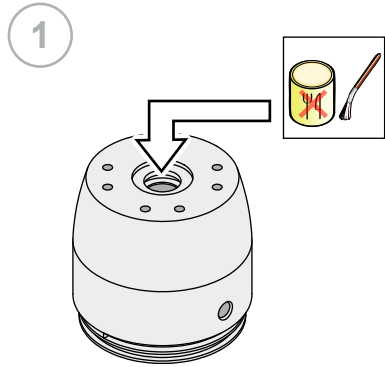

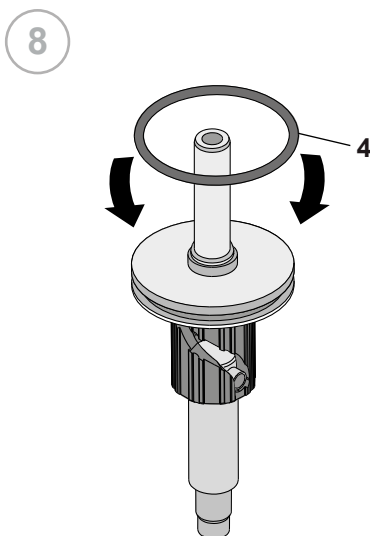
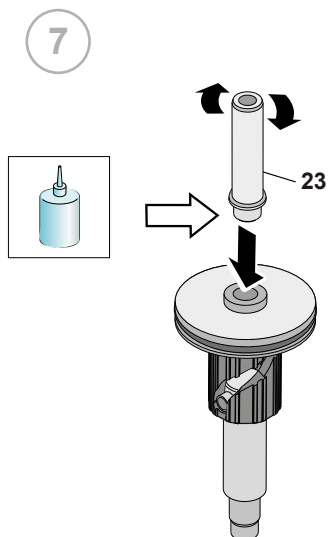
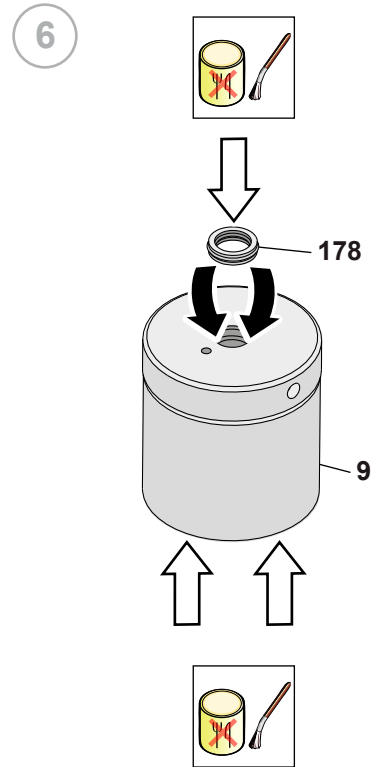
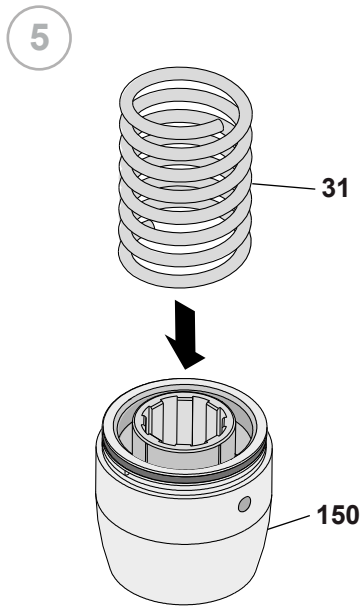

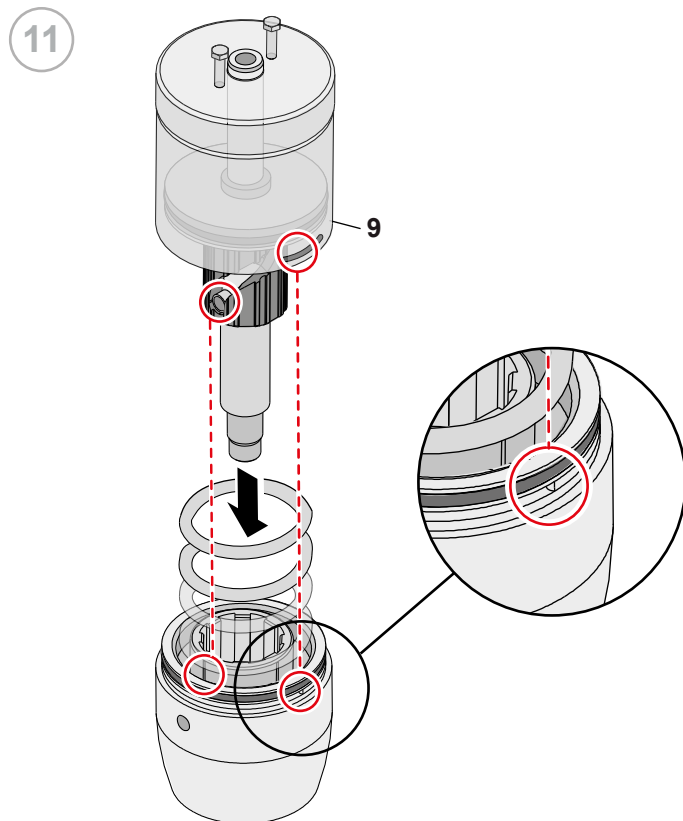
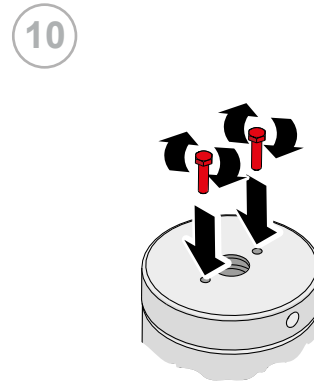
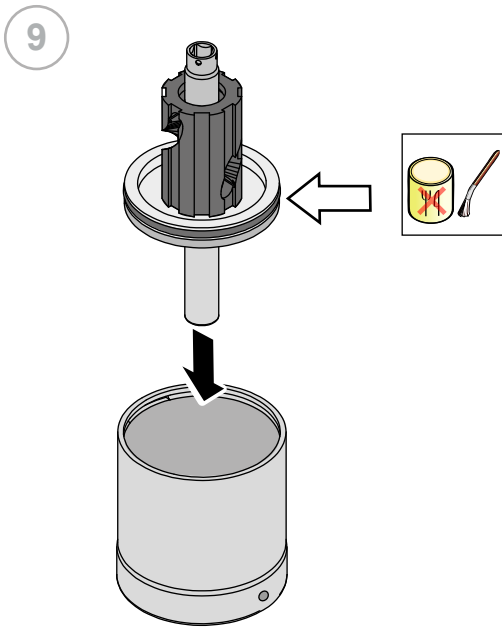

12

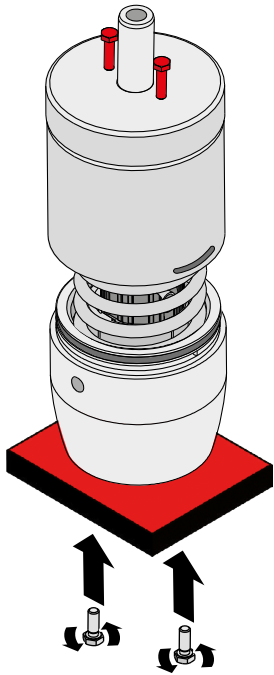

13

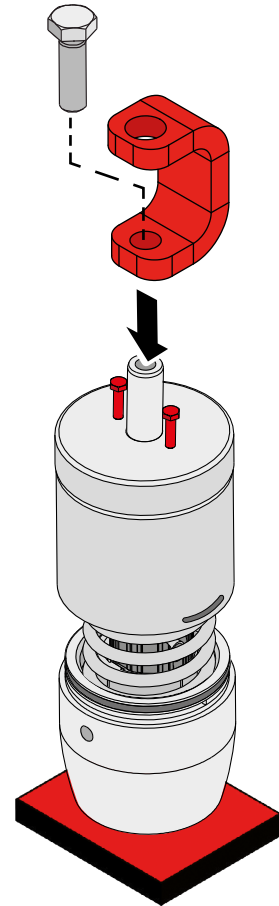

14

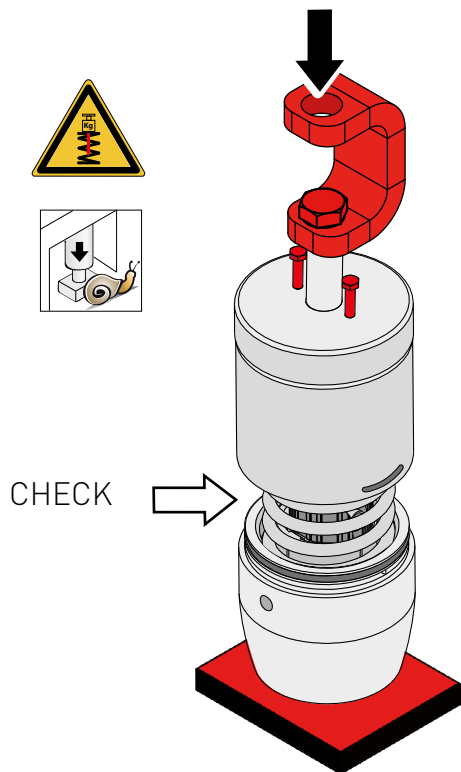

15

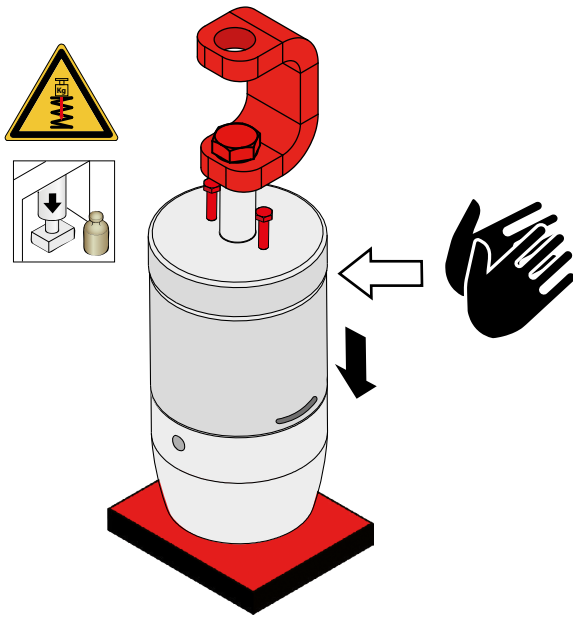

16

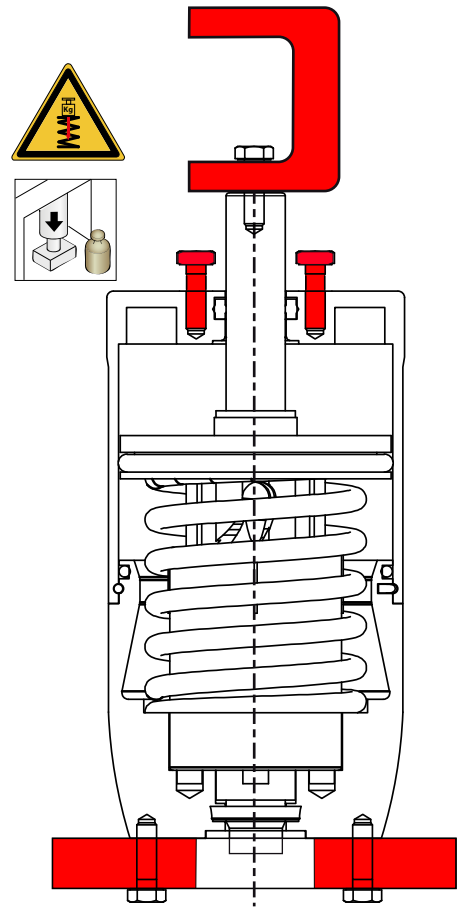

17

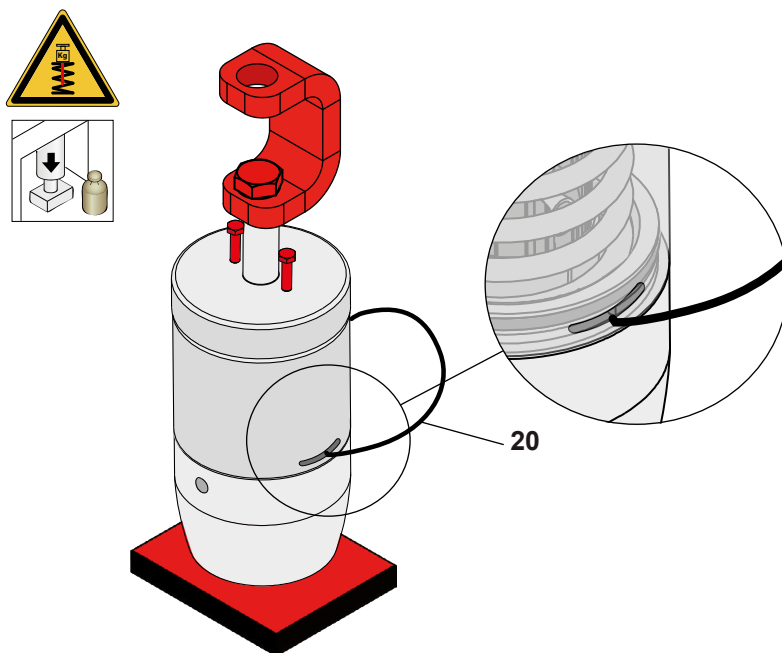

18

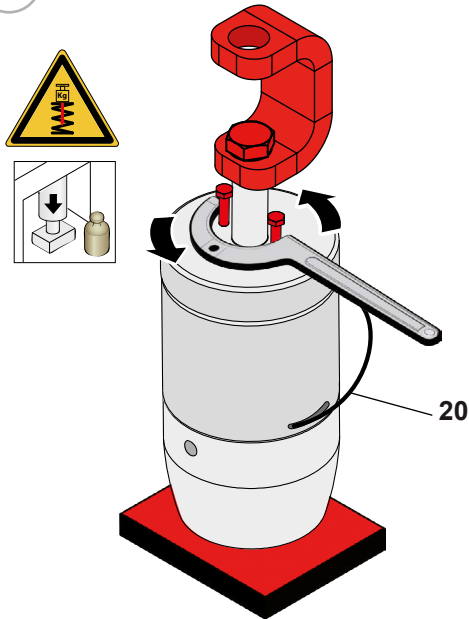

19

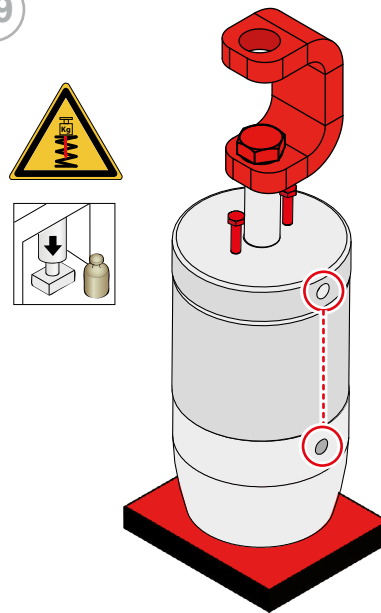

20

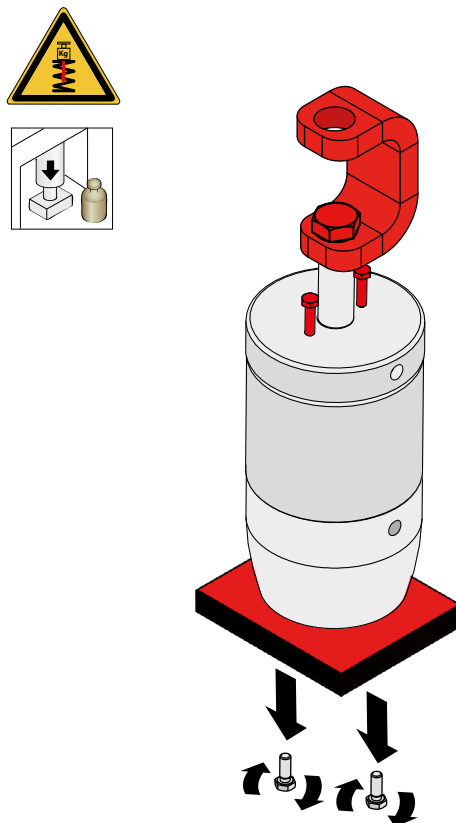

21

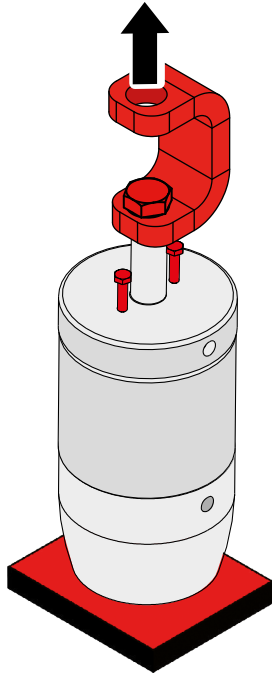
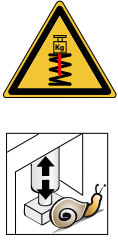

22

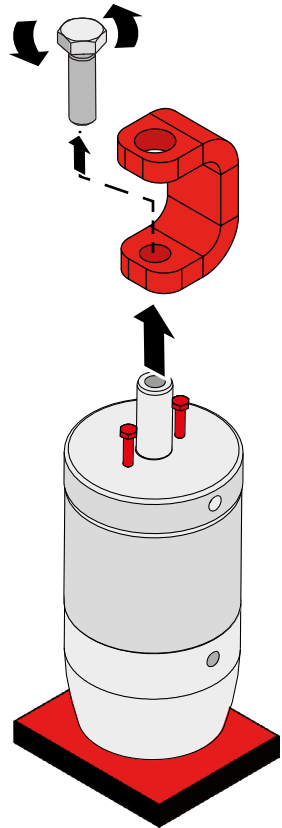

23

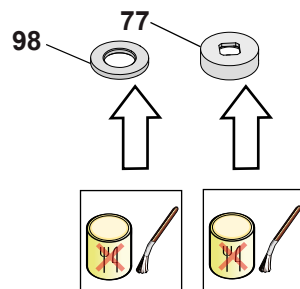

24

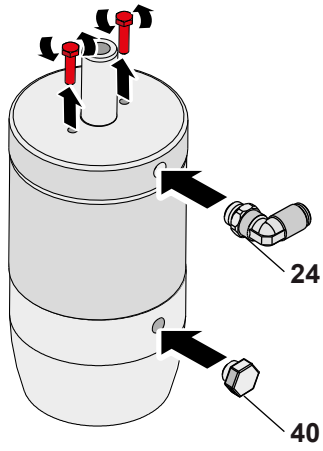

25

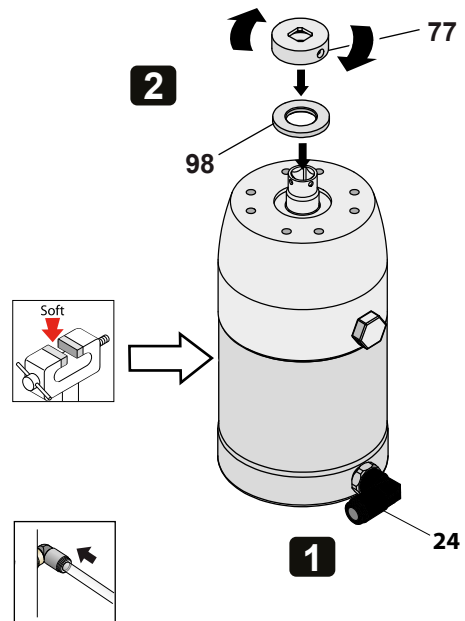

26

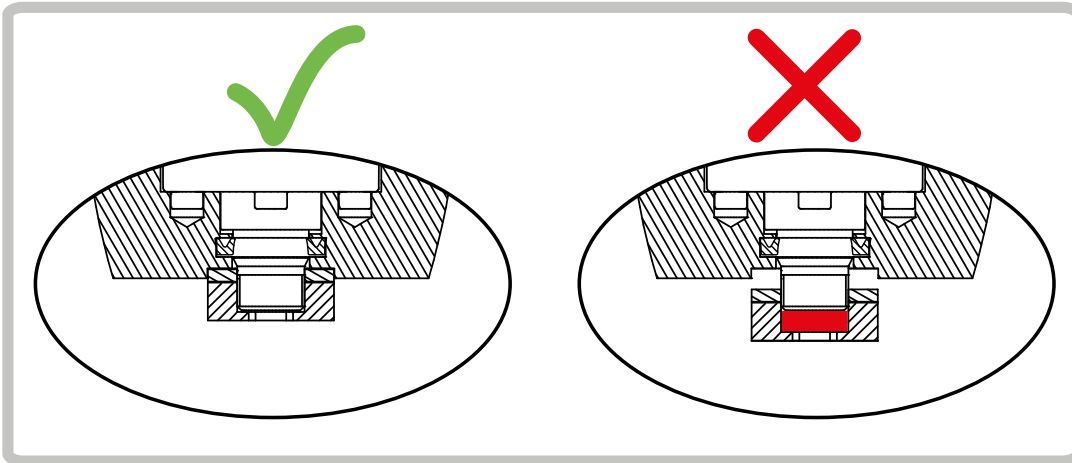

REGULATION



27

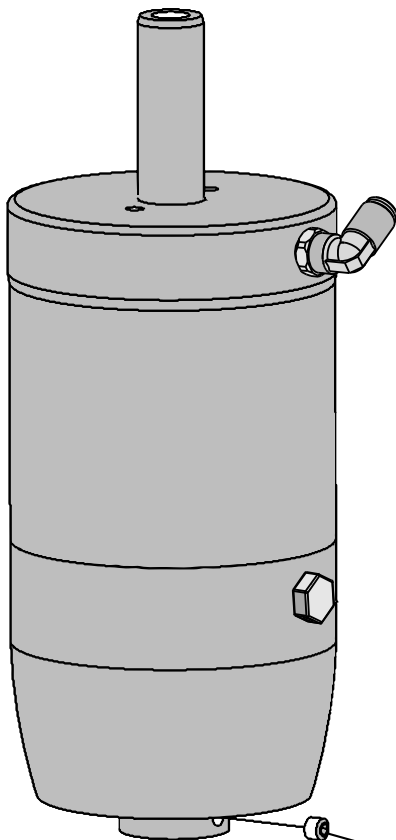

179

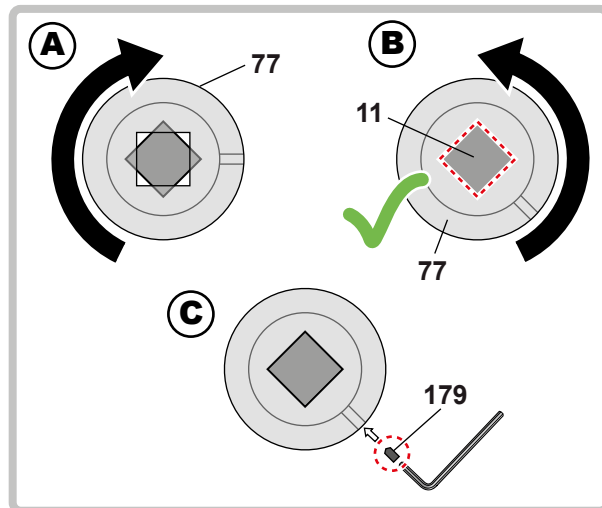

10.7 Pneumatic actuator MACH156

NO.	DESCRIPTION
4	Sealing ring
9	Actuator
11	Pin
13	Piston
16	Sealing ring
19	Sealing ring
20	Lock wire
23	Upper shaft
31	Spring
40	Plug
41	Pin
77	Nut
98	Insert
150	Threaded plug
158	Pipe
178	Sealing ring
179	Grub screw
282	Guide bush

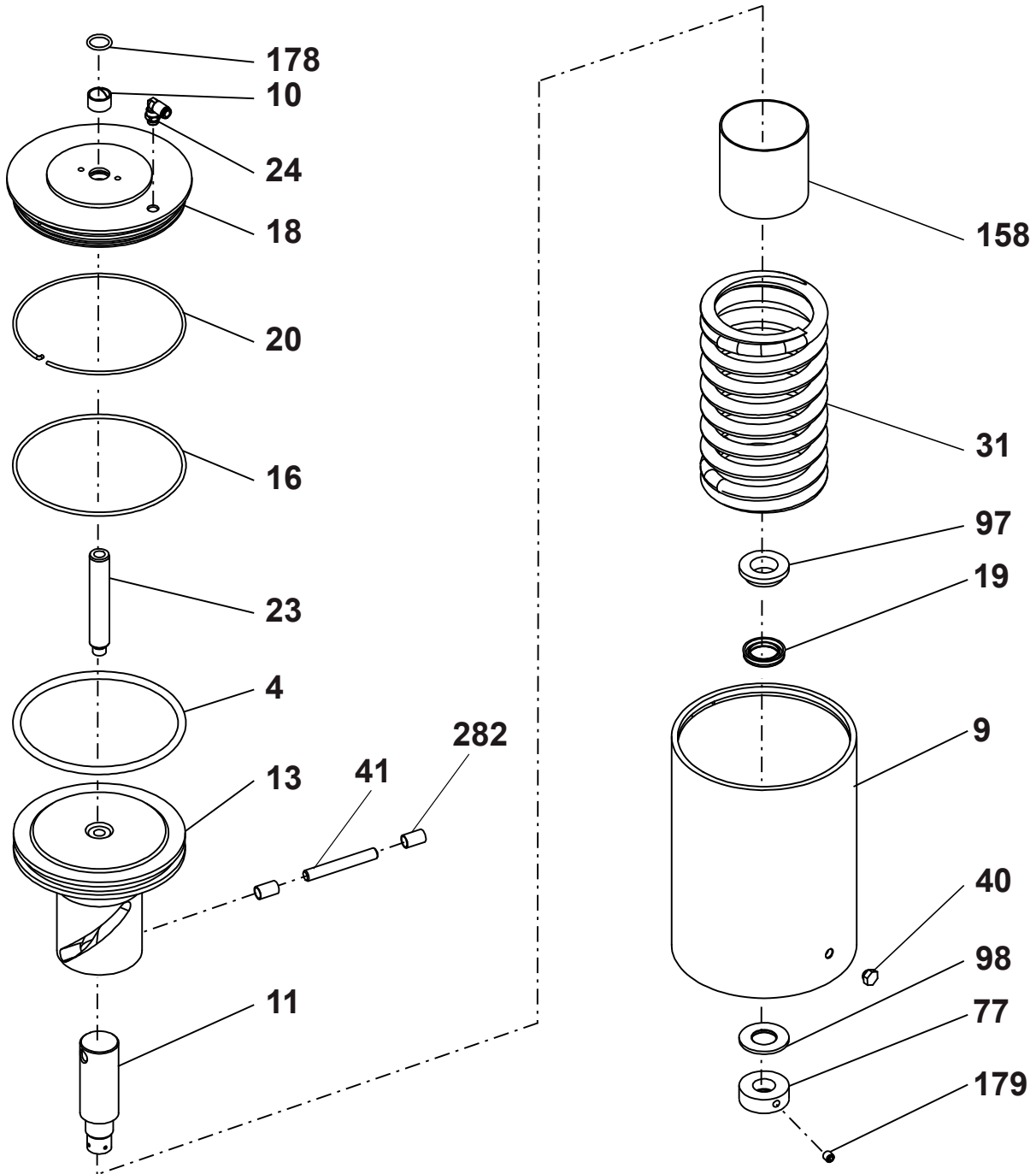

10.8 Disassembly of the MACH156

1

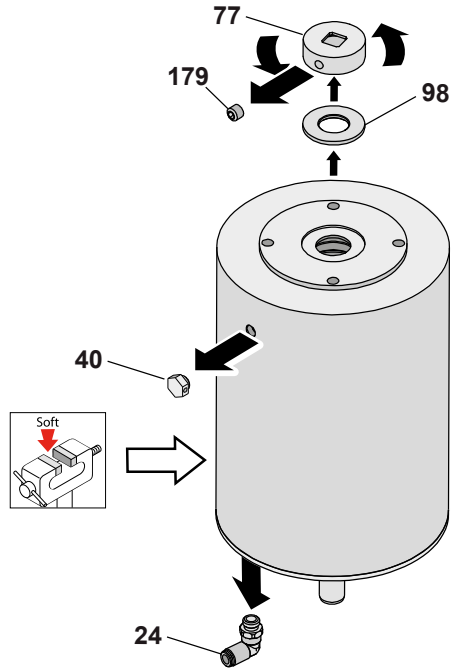

2

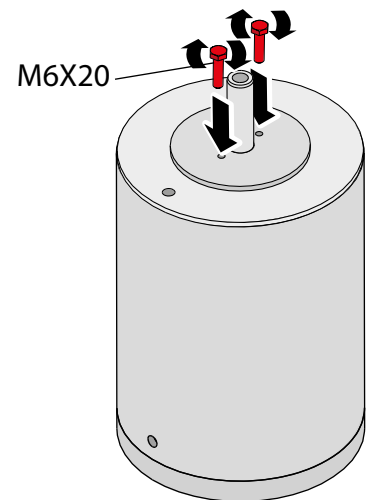

3

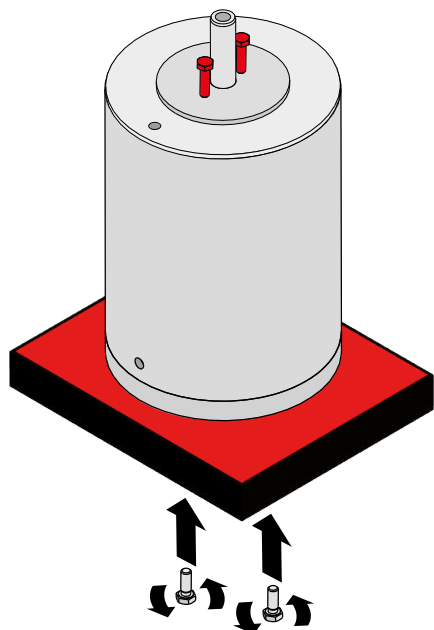

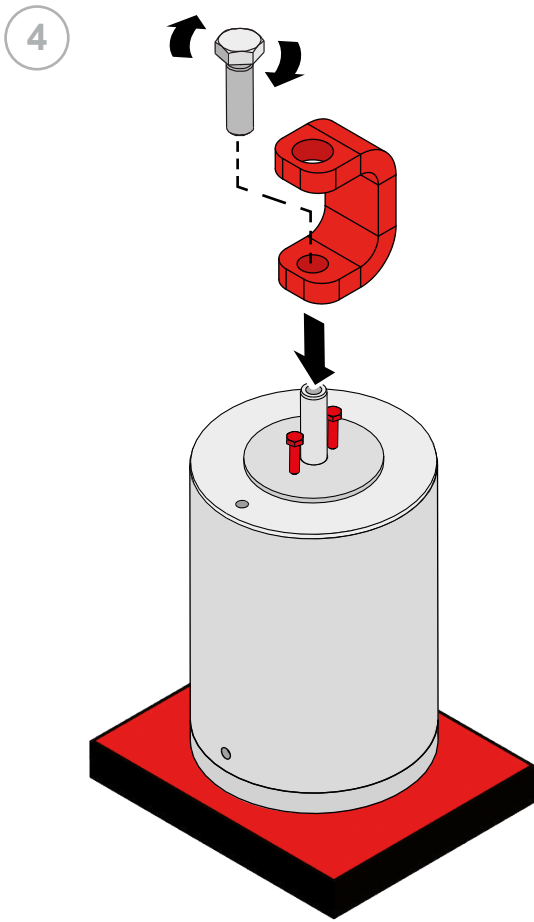

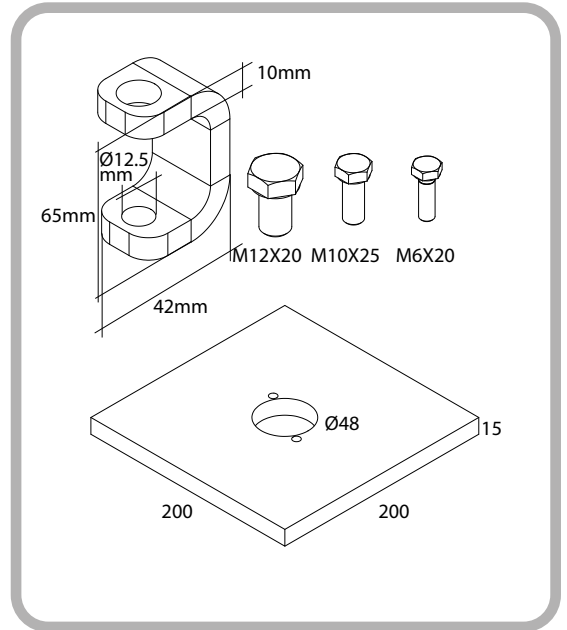
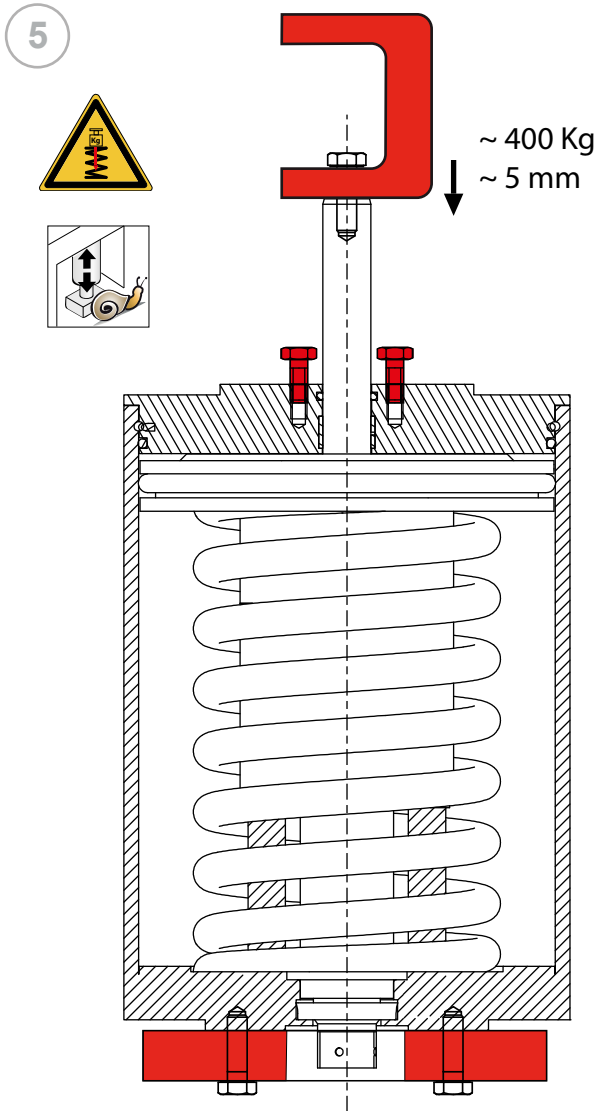

THESE ITEMS ARE NOT PROVIDED BY BARDIANI VALVOLE S.P.A.

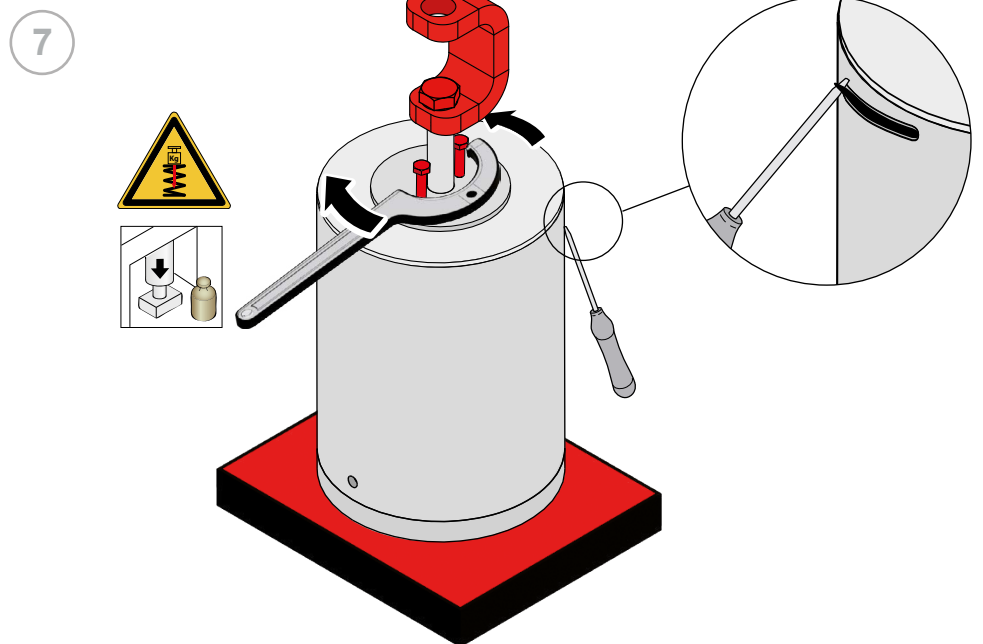

7

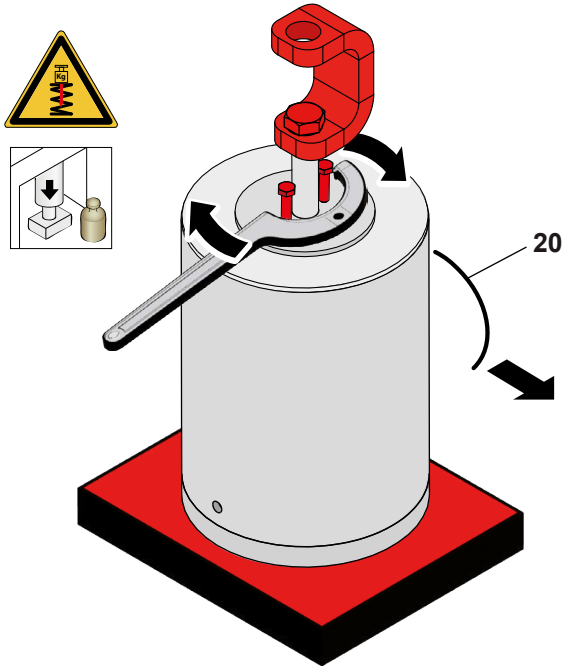

8

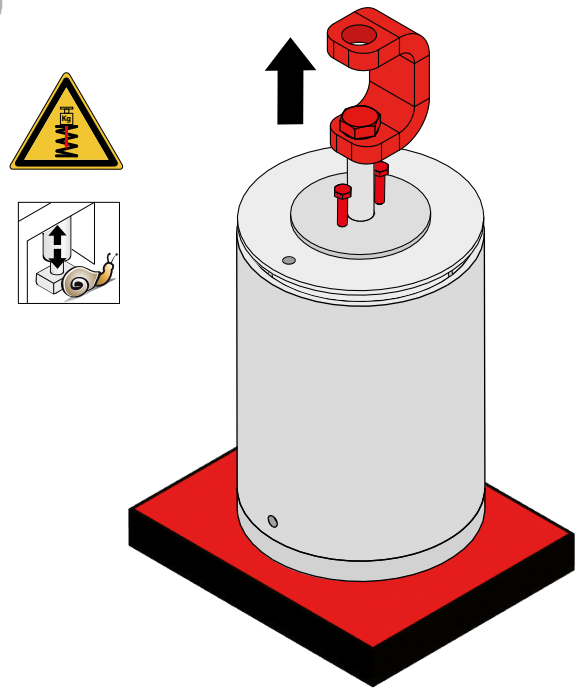

9

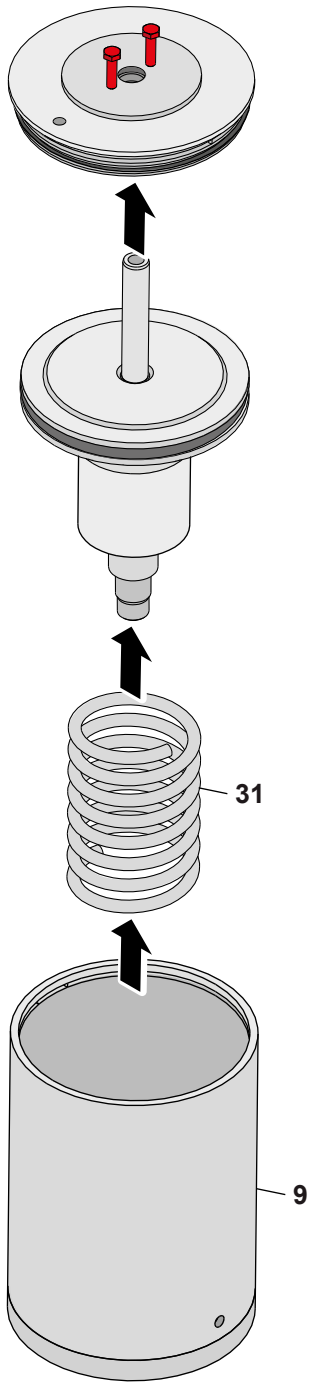

10

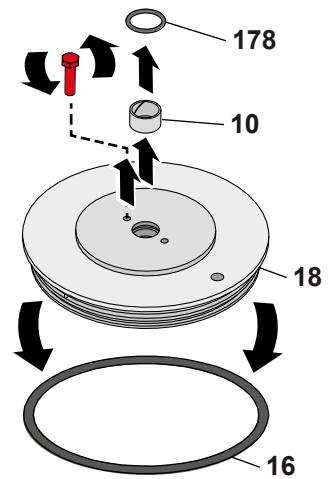

11

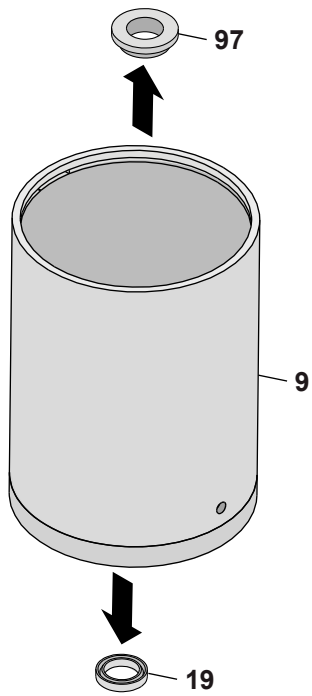

12

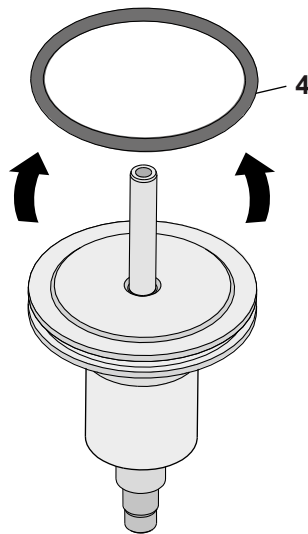

13

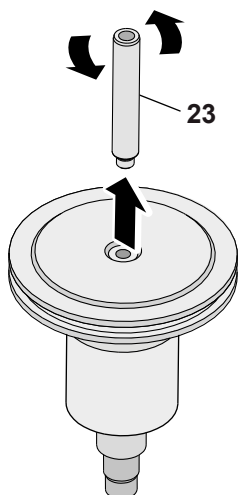

10.9 Assembly of the MACH156

1

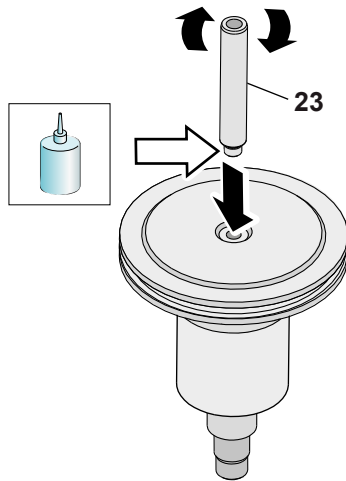

2

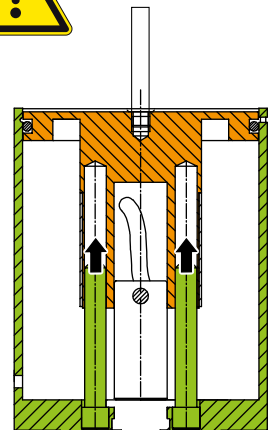
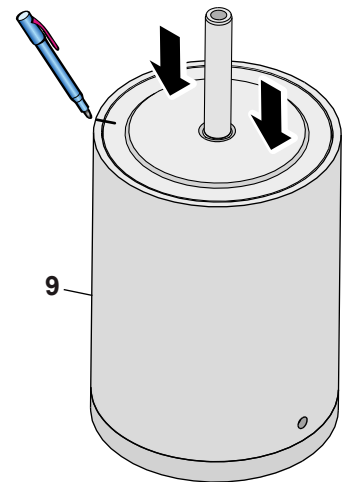

3

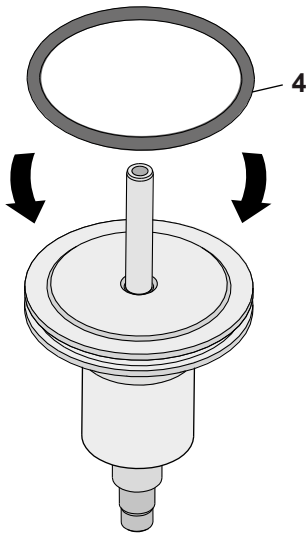

4

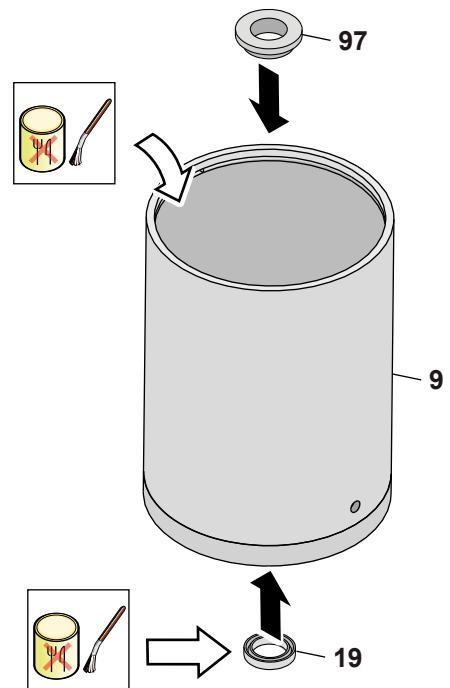

5

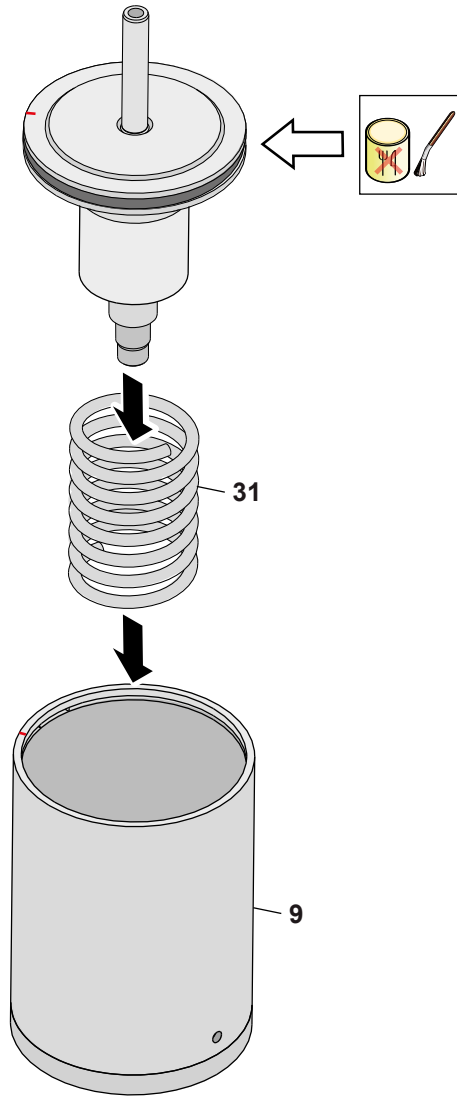

6

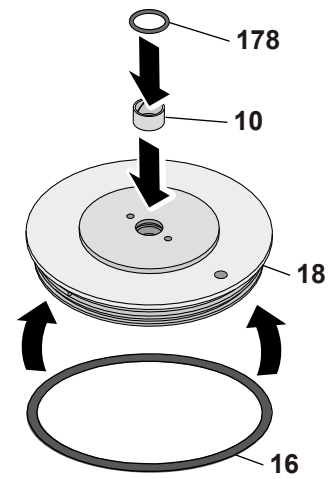

7

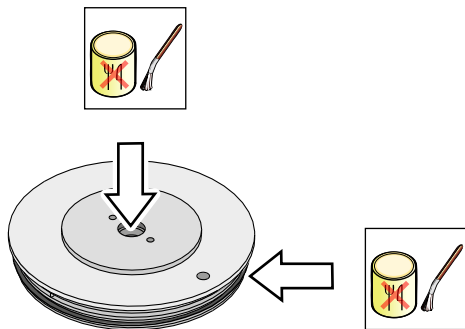

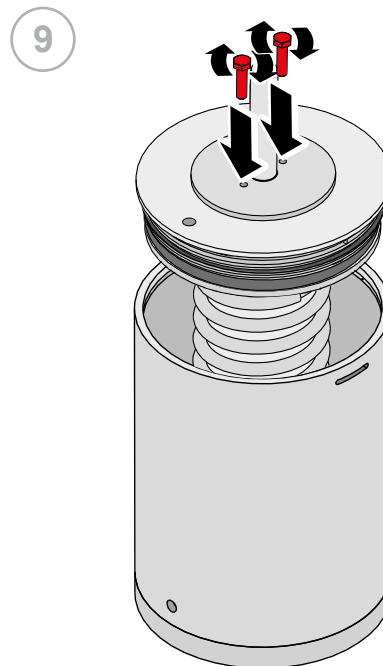
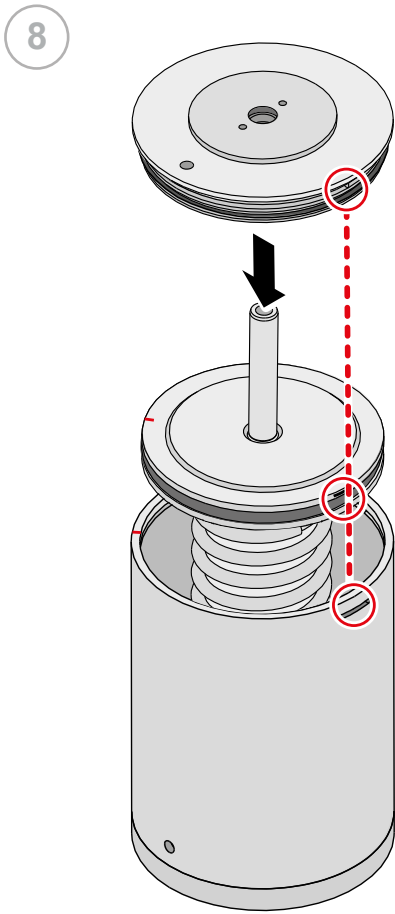

10

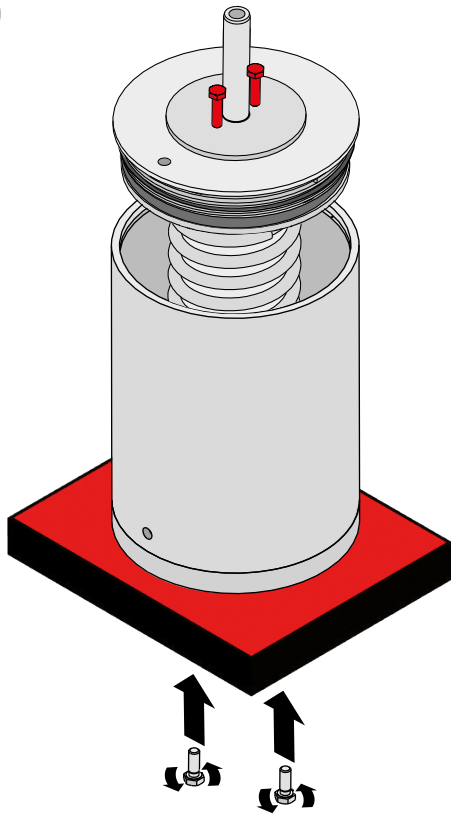

11

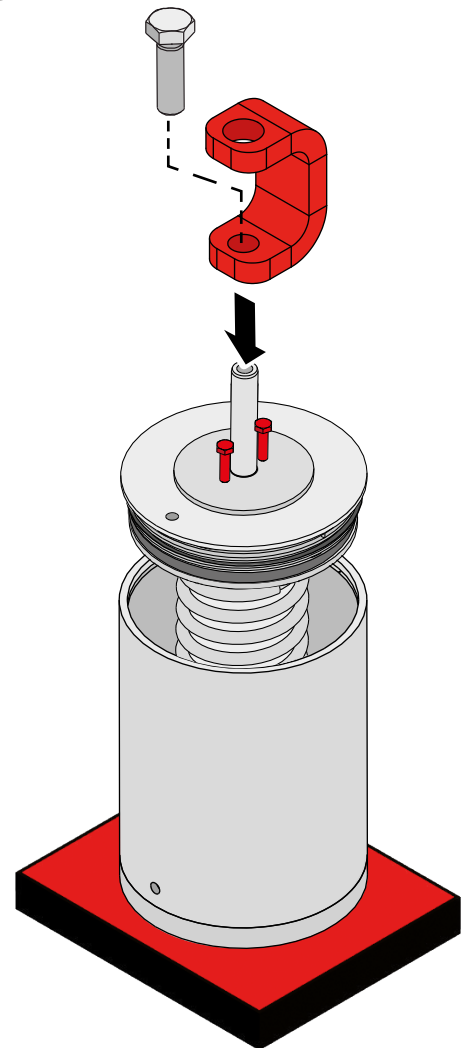

12

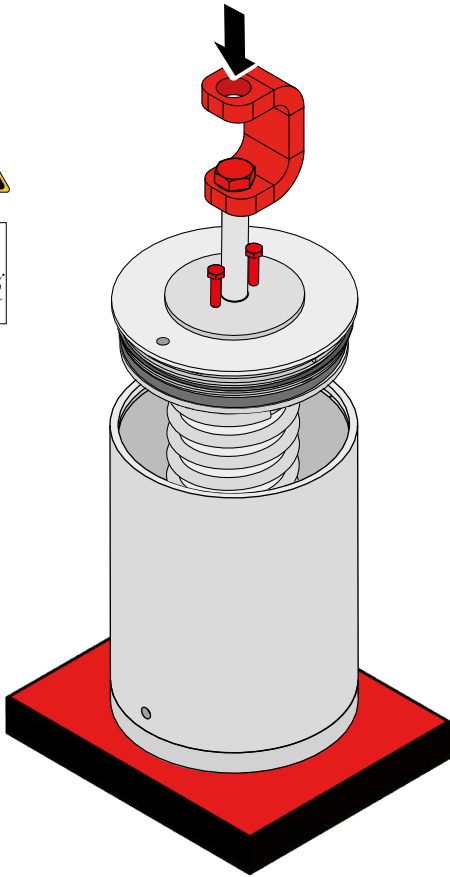
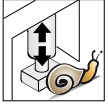

13

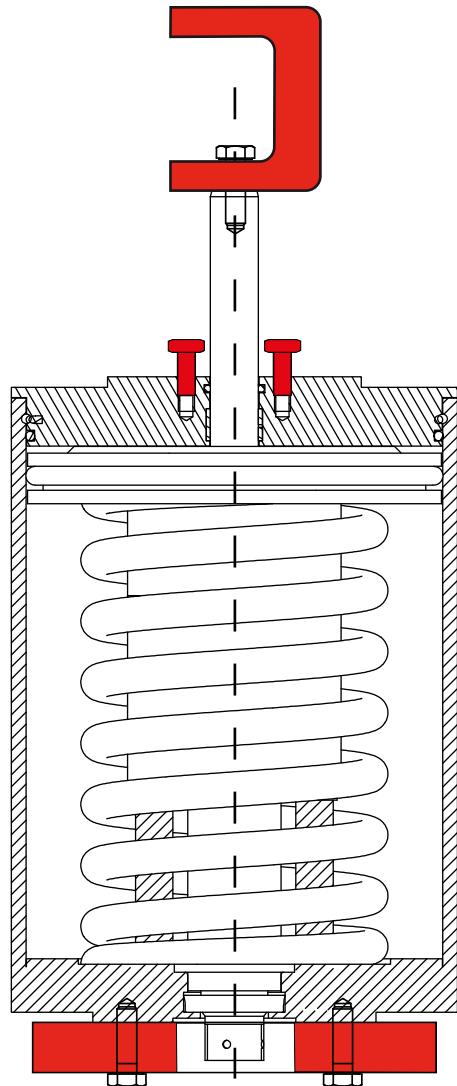
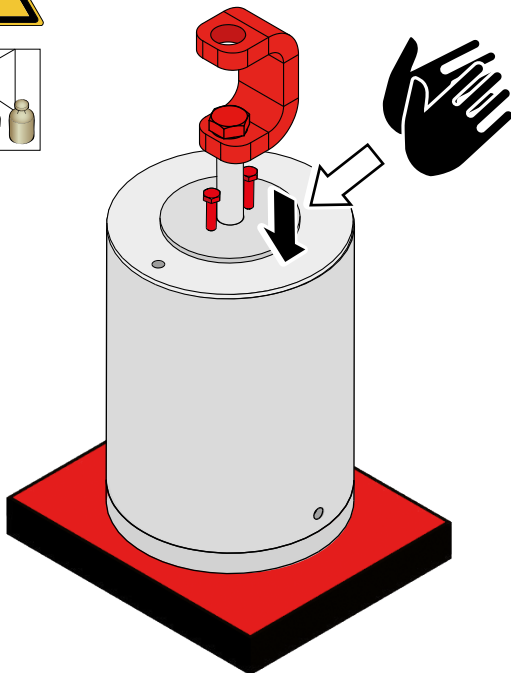
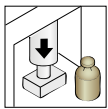

14

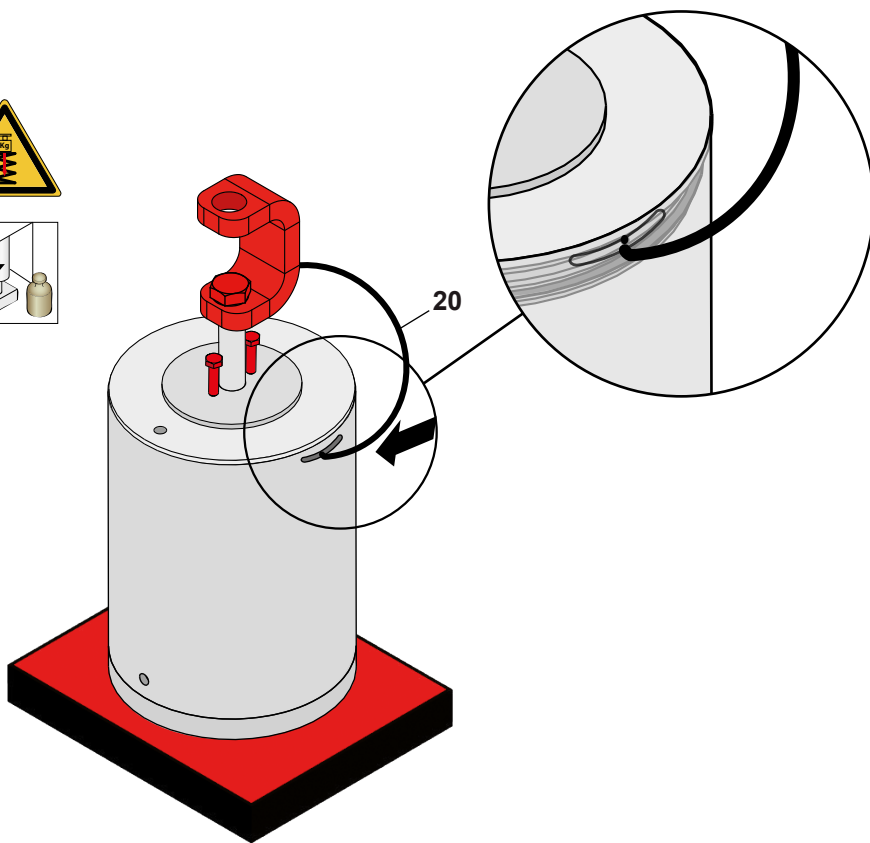
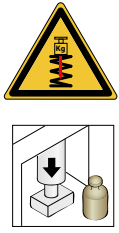

15

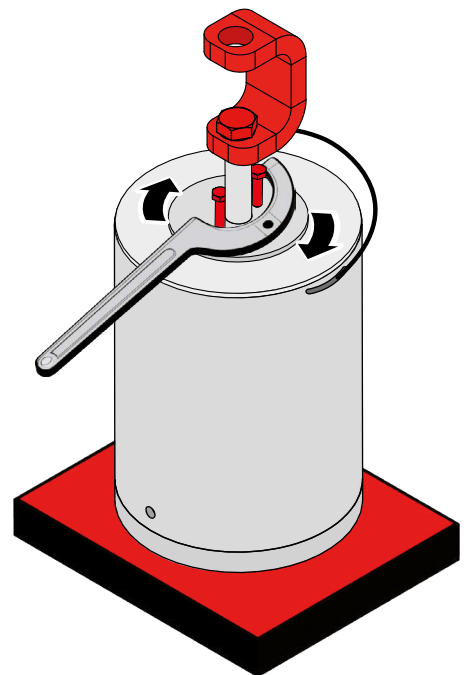
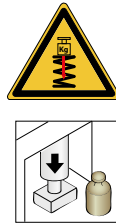

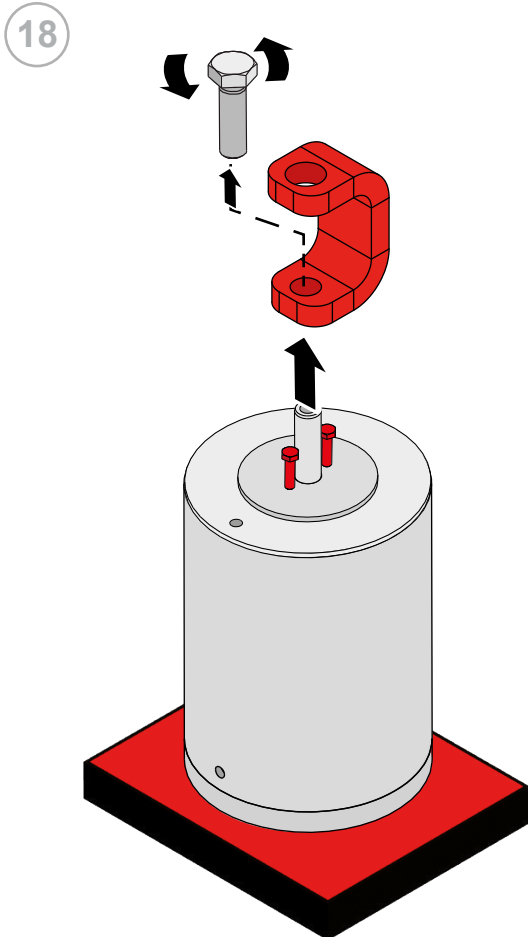
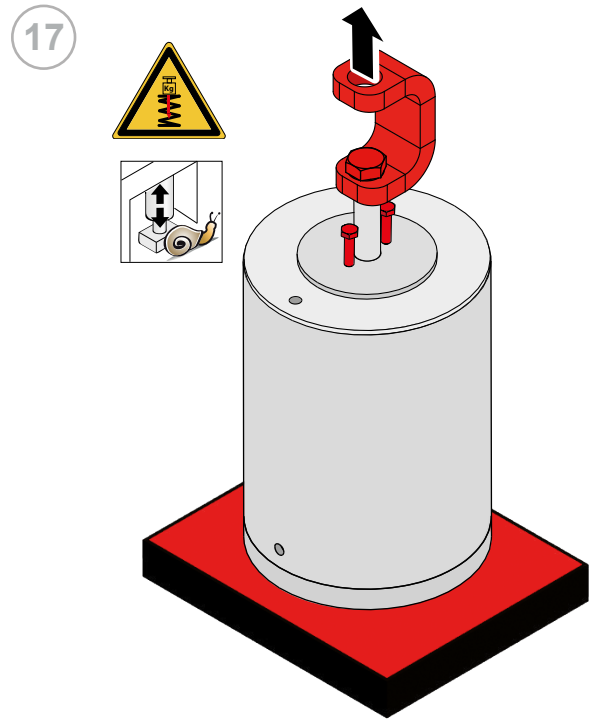
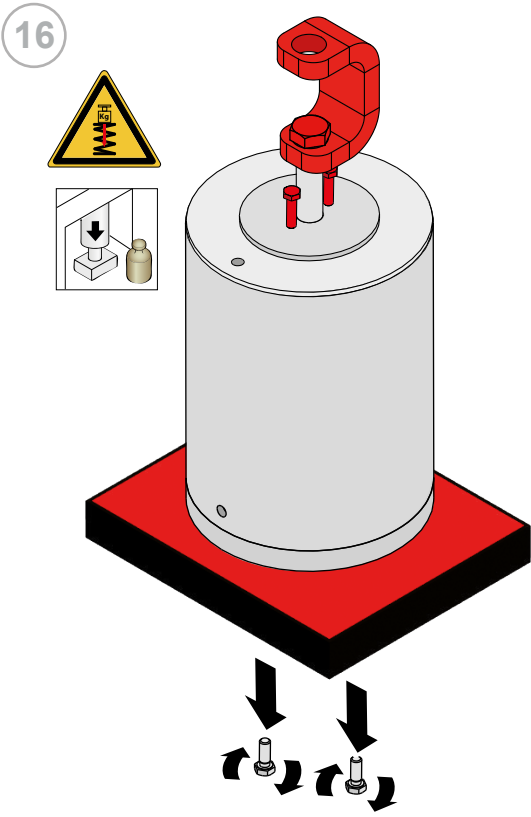

19

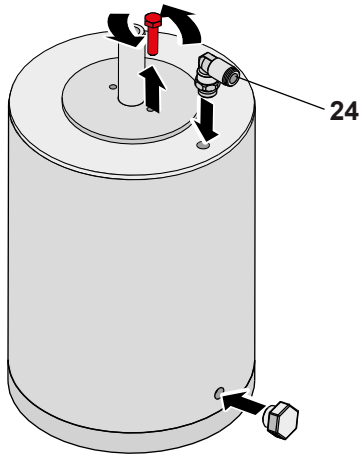

20

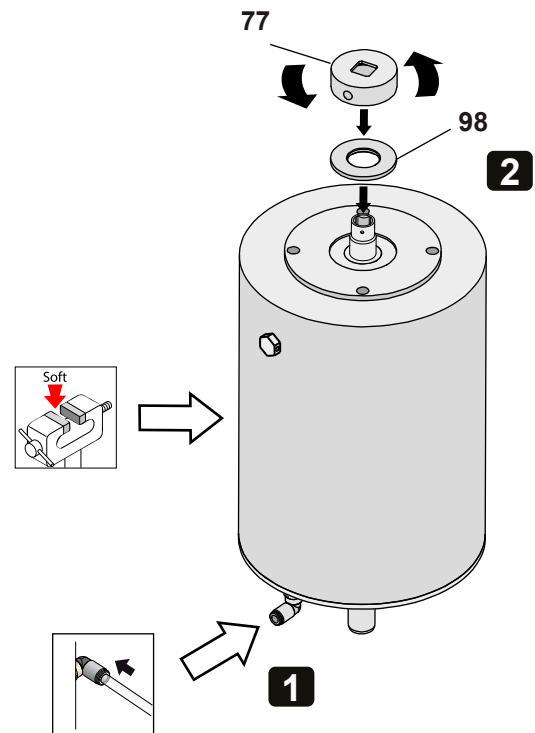

21

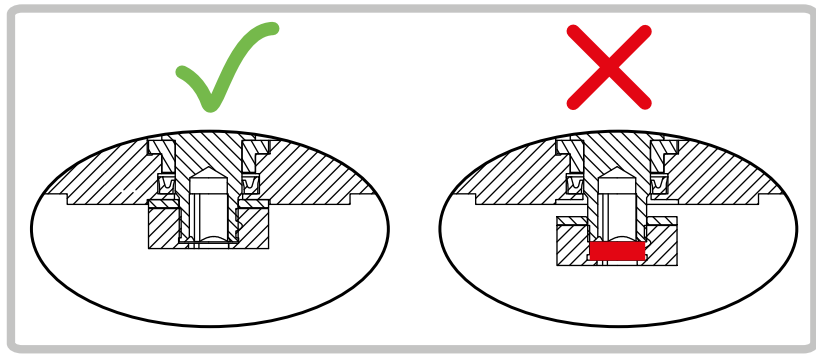

22

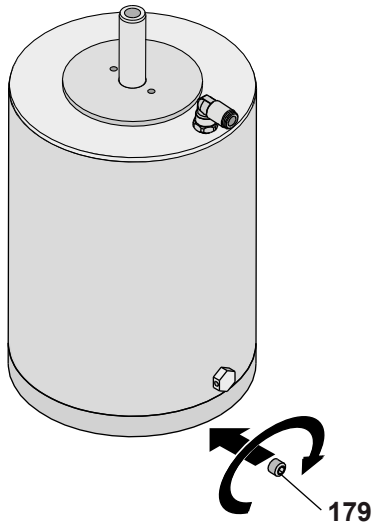

REGULATION

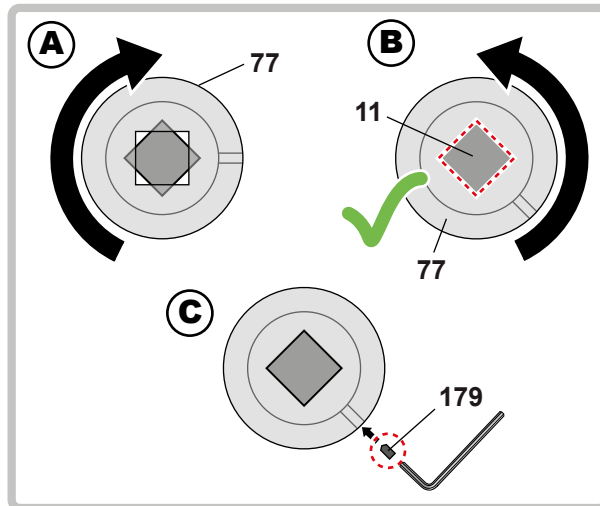

11 Annexes



A-A (1 : 1)

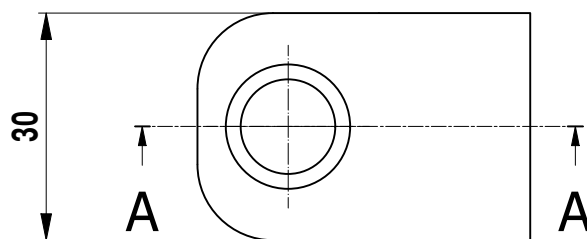
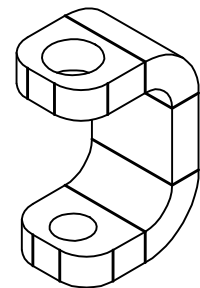
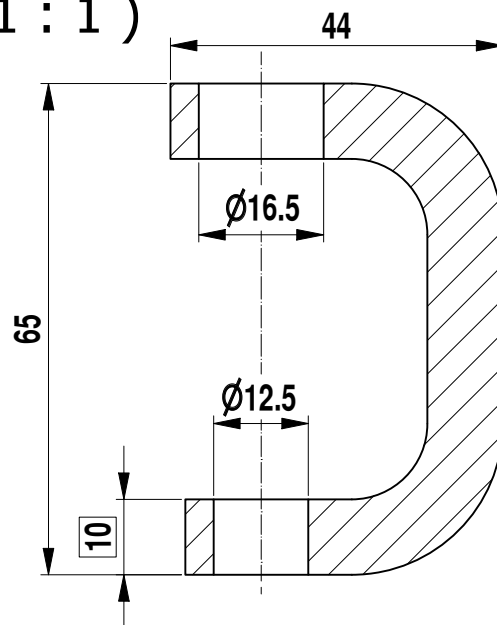

AISI304

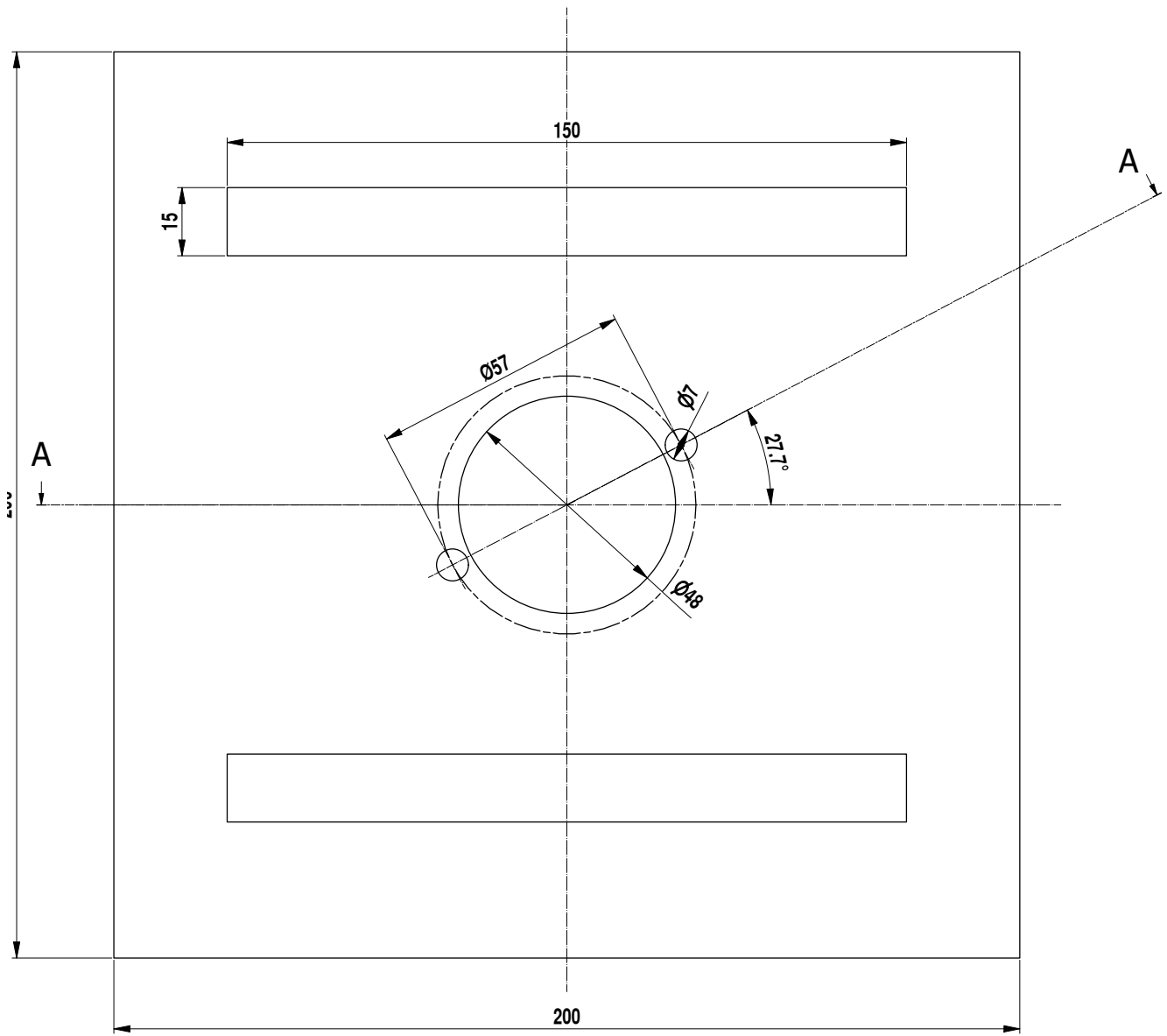

A-A (1 : 1)

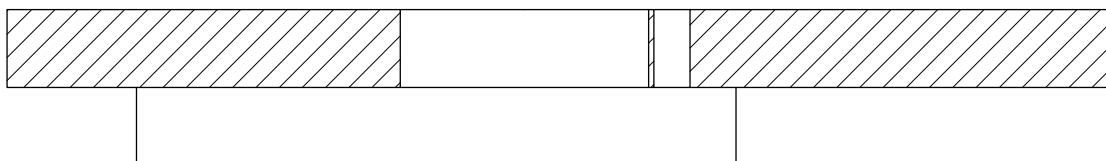

AISI304

12 2D diagram MACH 83-MACH98

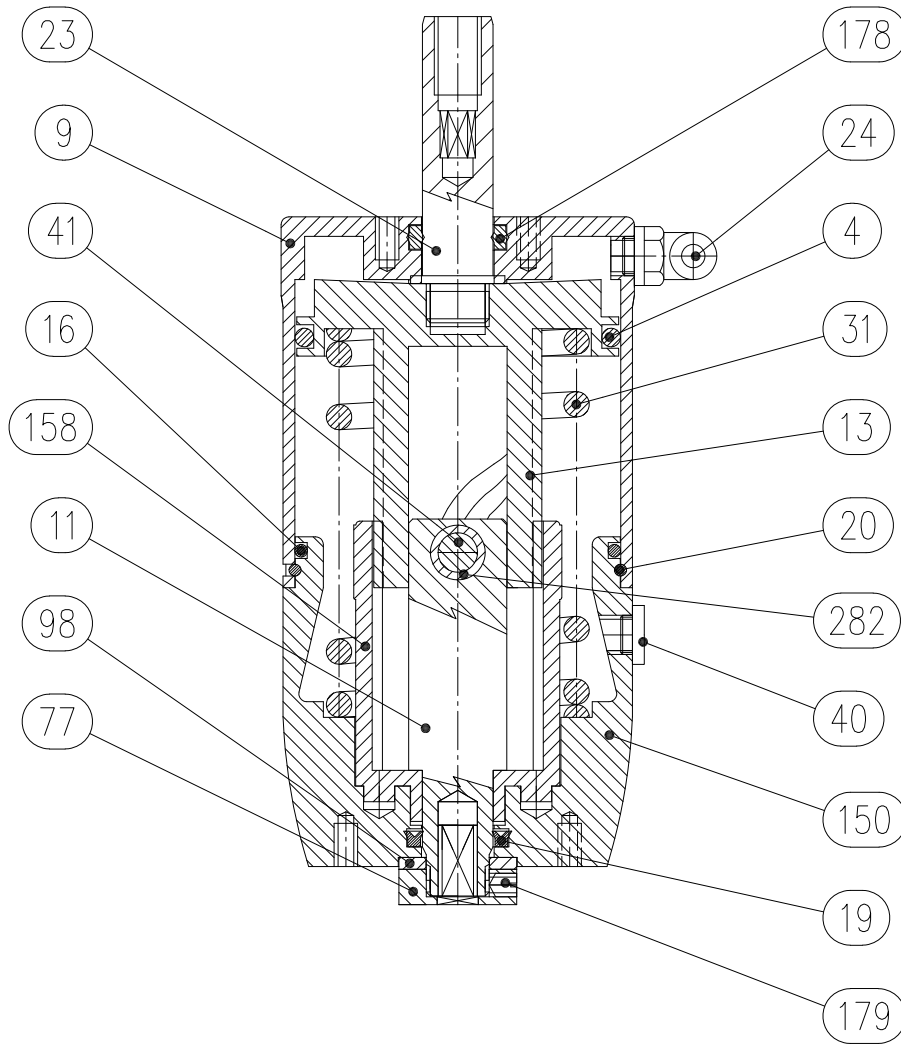

[A S MACH83-98]

13 2D diagram MACH156

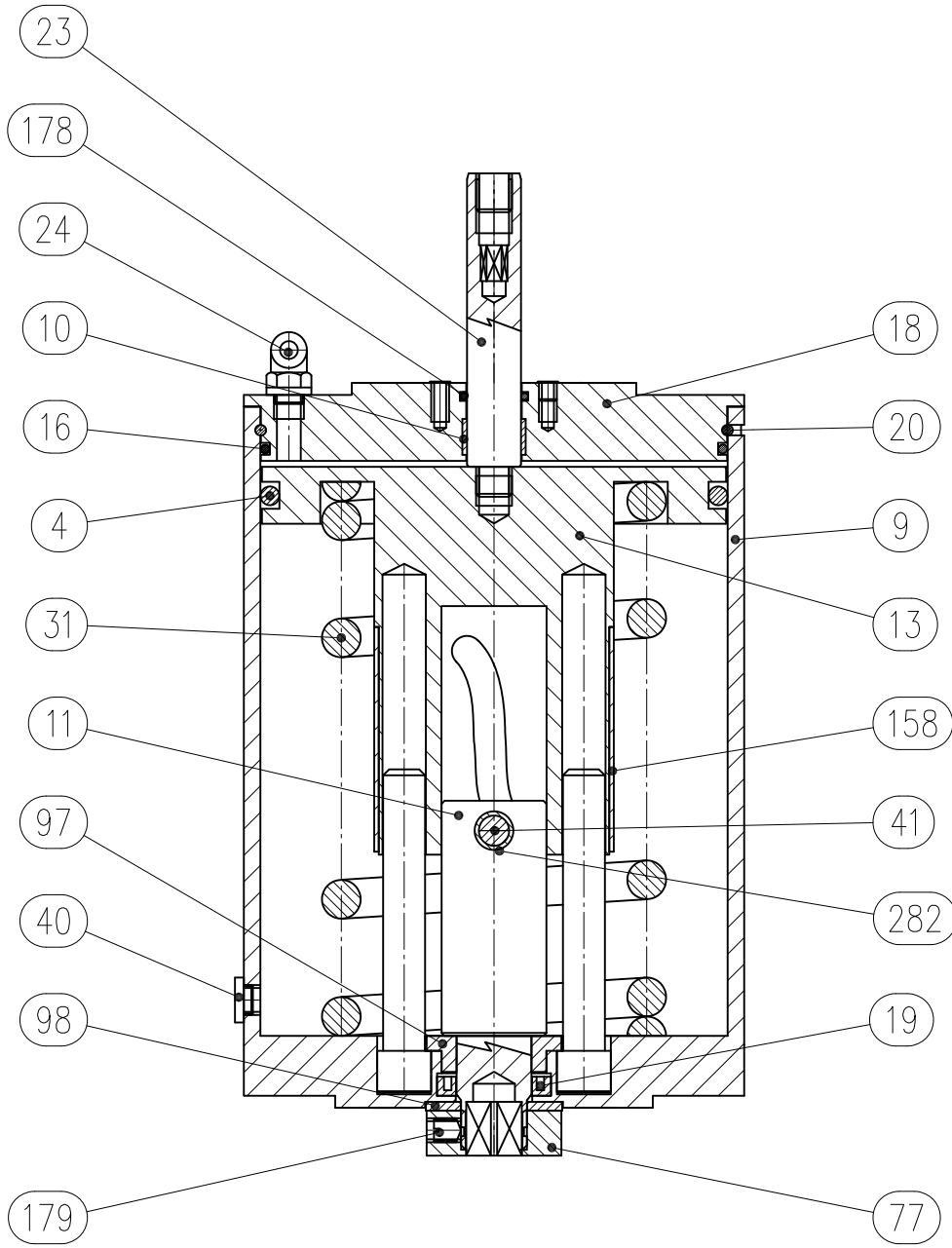

[A S MACH156]

14 Warranty

1. VALIDITY

Bardiani Valvole's Products are manufactured in compliance with the technical specifications laid out in their "Instruction, Use and Maintenance Manual" and are fully compliant with the directives specifically mentioned in these manuals.

Bardiani Valvole S.p.A. guarantees its own Products against any design and/or construction and/or material defects and/or faults for a period of 12 (twelve) months from the date of delivery.

Notification of any Product defects and/or faults must be sent in writing to Bardiani Valvole S.p.A. within 8 (eight) days from their detection, providing adequate documentation of the defect/fault encountered as evidence.

Services provided in the warranty period shall not result in an extension of the warranty beyond the stipulated 12 (twelve)-month period, as this warranty validity period is to be considered mandatory.

2. CONTENTS OF THE WARRANTY

Notwithstanding and without prejudice to the rights of the Buyer, which may be acknowledged by applicable law, this warranty is to be intended as limited, at the discretion of Bardiani Valvole S.p.A., to the repair and/or replacement of the Product and/or part of the Product and/or its components which is/are found to be defective due to design and/or manufacturing and/or material faults.

In the event of repair and/or replacement of the Product and/or any one of its parts and/or components, any returned item/s shall become the property of Bardiani Valvole S.p.A. and the relative shipping costs shall be charged to Bardiani Valvole S.p.A.

Bardiani Valvole S.p.A., shall be under no obligation to compensate for any immaterial and/or indirect damages and shall in no way be held liable for consequential damages and/or losses, such as (by way of example only), damages due to loss of business, contracts, opportunities, time, production, profits, goodwill, image etc.

No retailer or distributor or dealer or agent or representative or employee or person appointed by Bardiani Valvole S.p.A. is authorized to make any amendments and/or integrations and/or extensions to this warranty.

3. WARRANTY EXCLUSIONS

Elastomers are expressly excluded from this warranty.

This warranty does not cover design faults emerging whenever a Product is manufactured by Bardiani Valvole S.p.A. based on designs and/or technical specifications provided by the Buyer.

Moreover this warranty excludes the following:

- faults and/or defects resulting from incorrect and/or unsuitable and/or inadequate transportation of the Product;
- faults and/or defects resulting from failure to comply with the indications laid out in the "Instruction, Use and Maintenance Manual" with regards to installation of the Product or in any event caused by incorrect and/or unsuitable and/or improper installation;
- faults and/or defects resulting from failure to comply with indications laid out in the "Instruction, Use and Maintenance Manual" with regards to use and/or maintenance operations and/or storage of the Product or in any event caused by incorrect and/or unsuitable and/or improper use and/or maintenance operations and/or storage;
- faults and/or defects due to normal wear and tear of the Product and/or its parts and/or its components;
- faults and/or defects in the Product and/or its parts and/or its components for work and/or repairs being carried out by unskilled staff or staff that has not been authorised by Bardiani Valvole S.p.A.;
- faults and/or defects in the Product and/or its parts and/or its components due to it/them being dropped and/or banged and/or dented and/or misused and/or tampering and/or breakage and/or accidents or in any event due to negligence and/or carelessness and/or neglect by the Buyer and in general for any causes not attributable to design and/or manufacturing and/or material defects;
- faults and/or defects in the Product and/or its parts and/or its components caused by other events beyond the control of Bardiani Valvole S.p.A., such as force majeure or unforeseeable circumstances.

15 Recommendations

- 1.** Consultation of the "Instruction, Use and Maintenance Manual" is mandatory prior to the installation, use and maintenance of the products of all Products. All the information, indications, specifications, technical details provided herein are based on test data which the Manufacturer Bardiani Valvole S.p.A. holds to be reliable nevertheless the above is not deemed to be assumed as fully exhaustive inasmuch as not every possible use has been envisaged.
- 2.** All the illustrations and drawings provided are to be intended as indicative and therefore not binding, the illustrations being for presentation purposes only.
- 3.** It is the Buyer's duty to assess the suitability of the products for the use he intends to make of the same prior to placing the order as he/she will take the risks and accept liability in case of incorrect choice and use of the Products.
- 4.** The Manufacturer strongly recommends the Buyer to contact their sales team and request any information that might be needed in relation to the specifications and uses of the Products.
- 5.** The information provided in this manual refers to the standard products manufactured by Bardiani Valvole S.p.A. and therefore cannot be assumed to apply to customized products as well.
- 6.** Bardiani Valvole S.p.A. reserves the right to amend and/or integrate and/or update the data and/or information and/or technical details relative to Products at any time and without prior notice. Please visit the website www.bardiani.com, where the latest updated of the "Instruction, Use and Maintenance Manual" can be found".
- 7.** The content and validity of the warranty covering the Products of Bardiani Valvole S.p.A are dealt with in the relevant section in the "Instruction, Use and Maintenance Manual" which constitutes an integral part of the Products themselves.
- 8.** Bardiani Valvole S.p.A., shall not in any way be held liable for immaterial, indirect and consequential damages, such as (by way of example only), damages or loss of business, contracts, opportunities, time, production, profits, goodwill, image etc..

NOTES

Bardiani Valvole S.p.A.
via G. di Vittorio, 50/52 - 43045 Fornovo di Taro (PR) - Italy
tel. +39 0525 400044 - fax +39 0525 3408
bardiani@bardiani.com - www.bardiani.com