

GIOTTO TOP® TEACH

Bardiani Valvole S.p.A.

via G. di Vittorio, 50/52 - 43045 Fornovo di Taro (PR) - Italy

tel. +39 0525 400044 - fax +39 0525 3408

bardiani@bardiani.com - www.bardiani.com

INDEX

1	Safety, Warning and Mandatory Signs	5
1.1	Operator training	6
2	Intended purpose and safety	7
2.1	Intended purpose	7
2.2	General safety warnings	7
3	Technical data	9
3.1	Usage conditions	9
3.2	Mechanical data	9
3.3	Pneumatic data	9
3.4	Solenoid valve data	9
3.5	Electrical data, IO-Link	10
3.6	IO-Link specification	11
3.6.1.	Notes on IO-Link master configuration	11
3.7	Electrical data – AS-i	12
3.8	AS-i specification/Bit assignments	13
3.9	Electrical data – 24 Vdc	14
3.10	Electrical data – external (inductive) sensor	15
3.11	Position detection data	15
3.12	Details on electrical connections (IO-Link, AS-i, 24 Vdc)	16
4	Checking / Unpacking / Lifting	20
5	Installation of the Giotto Top Teach	21
5.1	External inductive sensor installation	22
6	Giotto Top Teach pneumatic connections	23
6.1	Manual override of the solenoid valves in the control unit	27
7	Position detection/visual feedback/teach functions	28
7.1	Position detection	28
7.2	Visual feedback (top LED)	29
7.3	Manual teach functions (MTF)	31
7.4	Automatic teach functions (ATF)	33
7.5	Reset functions	39
8	Error messages via top LED	42
8.1	Troubleshooting and error messages	44
9	Cleaning	45
10	Disposal	46
11	Maintenance	47
11.1	Components description	48
11.2	Assembly/ disassembly instruction of the Giotto Top Teach	50

12	Warranty	54
13	Recommendations	55

MANUAL REVISION	DATE

INTRODUCTION

This "Instruction, Use and Maintenance Manual" has been drawn up expressly for expert technical personnel. Consequently any information which can easily be deduced from reading the text and/or examining the illustrations and/or drawings provided herein shall not be the object of further explanation.

This "Instruction, Use and Maintenance Manual" forms an integral part of the control unit. Before proceeding with installation, use or maintenance of each type of control unit it is compulsory to read and understand this manual.

This manual must be kept for all future reference







It being understood that the essential characteristics of the type of control unit described herein shall remain the same, the manufacturer reserves the right to amend and/or integrate and/or update the data and/or information relative to use of the control unit provided in the "Instruction, Use and Maintenance Manual", at any time and without prior notice.

The latest, updated version of the "Instruction, Use and Maintenance Manual" is always available at www.bardiani.com

The manufacturer shall not in any way be held liable for any consequences resulting from a failure to correctly observe the prescriptions provided in the relative manual concerning installation, use, maintenance and care of the Product.

All rights reserved. It is prohibited, without prior written authorization from the manufacturer, to totally and/or partially reproduce and/or transmission and/or record any part of this "Instruction, Use and Maintenance Manual" using any means and/or support, including IT and/or electronic and/or mechanical and/or paper formats, or by means of any other system to save and/or reuse it for purposes different to the exclusive use by the purchaser.

1 Safety, Warning and Mandatory Signs

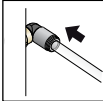
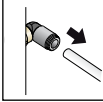
SIGNALS		
Pictogram	Description	Notes
	WARNING General	This tells the person in question that the operation described involves (when not performed in accordance with the relative safety regulations) the risk of personal injury.
	OBLIGATION General	Special instructions must be followed to avoid injury to persons.
	SKILLED PERSONNEL	Dismantling/Assembling and maintenance operations must be carried out by expert technicians only.
	NOTE	Follow the given instructions.
	ELECTRICAL CONNEC- TION	Electrical connection to the control unit
	ELECTRICAL DISCON- NECTION	Electrical disconnection from the control unit
	PNEUMATIC CONNEC- TION	Compressed air connection to the control unit
	PNEUMATIC DISCON- NECTION	Compressed air disconnection from the control unit.

OPERATING SIGNS		
Pictogram	Description	Notes
	APPLICATION OF NSF H1 GREASE	Use only FOODLUBE HI-TEMP 2 grease or equivalent

1.1 Operator training



All persons who have to work on the control unit must be qualified to carry out the relative maintenance tasks.

They must be informed as to the possible hazards involved and must observe all the safety instructions set out in this manual.

Allow expert personnel only to work on the electrical components.

2 Intended purpose and safety

2.1 Intended purpose



Intended purpose

The control unit has been developed to actuate process valves with compressed air pneumatic actuators manufactured by Bardiani Valvole S.p.A..

- The Giotto Top Teach control unit can be equipped with a maximum of three solenoid valves (MS, LL, UL*) to actuate the process valve.

Feedback signals of the non-contact, analogue position detection (depending on the variant for the teach positions S1 to S3) and optionally a position signal S4 (external sensor), which are fed back to the control system, are used to detect the process valve positions (see also 7.1 Position detection for single cam).

- Top LED: a central visual feedback signal indicates the detected process valve status:
 - green stands for process valve "open";
 - yellow for process valve "closed";
 - white for "lower" or "upper" lift stroke enabled.

Additional colour signals are listed in sections

7.2 Visual feedback (top LED)

7.3 Manual teach functions (MTF)

7.4 Automatic teach functions (ATF).

7.5 Reset function

- Configurations are provided for the electrical connections in the control unit and the communication: IO-Link (Port Class A and B), AS-Interface, 24 Vdc.

Non-intended use

The control unit must not be used:

- for processes other than those intended

2.2 General safety warnings



BARDIANI VALVOLE S.p.A. declines all liability for installation, operation and maintenance contrary to the provisions of these instructions!

General notes

- Always read the technical data carefully before machine installation, operation and maintenance.
- The Giotto Top Teach must always be installed, operated and maintained by authorized personnel. Said personnel must know and understand both the unit and the contents of the manual.
- Take care over any separate parts of the Giotto Top Teach when removing it from its packaging.
- Always connect the air supply carefully and disconnect it after use.
- Always connect the power supply carefully and disconnect it after use.
- Never touch the moving parts in the Giotto Top Teach or valves.
- Always handle detergents with care.

*MS: main stroke LL:lower lift UL:upper lift

**WARNING**

The control unit may not be used inside premises where there is a potentially explosive atmosphere or risk of fire unless otherwise stated by the manufacturer (in the case of valves certified in accordance with Directive 2014/34/EU please refer to the ATEX Manual).

**WARNING****North America – Observe UL508A standard!**

The control unit contains circuits classified as LOW VOLTAGE LIMITED ENERGY CIRCUIT. For correct use in North America, the protective circuits must be designed in accordance with the UL508A standard.

**WARNING****Risk of injury from electrical voltage and high pressure!**

Always MAKE SURE that the supply voltage is correctly selected (between 18 and max. 31.6 Vdc, depending on the variant) and that the electrical and compressed air connections are NOT enabled when interventions are carried out on the Giotto Top Teach control unit.

3 Technical data

3.1 Usage conditions

OPERATING AND AMBIENT CONDITIONS/STORAGE CONDITIONS	
Ambient temperature	-10 to +55 °C
Degree of protection	IP67 as per EN 60529
Storage temperature/storage conditions	-10 to +25 °C/dry, dust free, low vibration
Vibrations	Sinusoidal test according to IEC60028-2-6 Frequency range 10-150 Hz Transition frequency 60 Hz Vibration amplitude (below the transition frequency) 0,3 mm Acceleration (above the frequency transition) 50m/s (5g)

3.2 Mechanical data

MECHANICAL DATA	
Weight	approx. 0.55 kg to 0.65 kg depending on configuration
Housing material (no media contact)	PA6 GB30 (Material circuit board holder); PA66+PA6-GF30 (housing)
Seal material	NBR/EPDM

3.3 Pneumatic data

PNEUMATIC DATA	
Supply air pressure range	max. 7 bar min. 6 bar
Air supply (quality)	Class 2,4,3 in accordance with ISO 8573-1 (filter 5 µm recommended)
Air supply and vent connections thread	1/8" (BSP)
Air supply OD	6 mm or 1/4"
Air connection 1,2,3 OD	6 mm

3.4 Solenoid valve data

TECHNICAL DATA OF THE SOLENOID VALVES	
Solenoid valve types	3/2-way / Type 6510 NC* (with 9-V coil) 3/2-way / Type 6510 NO** (with 9-V coil)
Manual override of solenoid valve	see Section 6.1 Manual override of the solenoid valves in the control unit

APPLICATION CRITERIA OF THE SOLENOID VALVES	
Single-acting process valves	1 Solenoid valve NC*
Double-acting process valves - with 1 solenoid valve NO** and 1 solenoid valve NC* with joint control electronics;	2 solenoid valves: NO** + NC*
- Mixproof double seal and twin-stop process valves (with 2 solenoid valves NC*)	2 solenoid valves
Mixproof process valves with air supply for opening and lower (LL) and upper lift (UL)	3 Solenoid valves NC*

* NC = normally closed

** NO = normally open

In the event of any doubt, please contact Bardiani Valvole SpA.

3.5 Electrical data, IO-Link

ELECTRICAL DATA, IO-LINK	
Power supply of control unit	18 to 30 Vdc in accordance with IO-Link specification (protection class 3 in accordance with DIN EN 61140 (VDE 0140-1))
Electrical connections (POWER 1/POWER 2)	Port Class A: M12 plug (4-pin) Port Class B: M12 plug (5-pin) See also section 3.12 Details on electrical connections (IO-Link, AS-i, 24 Vdc)
Current consumption – max.: (i.e. 2 solenoid valves enabled, 1 solenoid valve switches on (for 200 ms), 1 position feedback via Top LED, no external sensor)	Port Class A (POWER 1): smaller than 151 mA at 24 Vdc Port Class B (POWER 1): smaller than 63 mA at 24 Vdc Port Class B (POWER 2): smaller than 97 mA at 24 Vdc
Current consumption in persistent state: (i.e. 3 solenoid valves enabled, 1 position feedback via top LED, no external sensor)	Port Class A (POWER 1): smaller than 138 mA at 24 Vdc Port Class B (POWER 1): smaller than 63 mA at 24 Vdc Port Class B (POWER 2): smaller than 84 mA at 24 Vdc
Idle current: (i.e. no solenoid valves enabled, no position feedback via top LED, no external sensor)	Port Class A (POWER 1): smaller than 42 mA at 24 Vdc Port Class B (POWER 1): smaller than 42 mA at 24 Vdc Port Class B (POWER 2): smaller than 9 mA at 24 Vdc
Current consumption top LED	approx. 21 mA at 24 Vdc
Inputs (control unit > IO-Link master/PLC) / binary or analogue feedback signals	The recovery of the 3 valve positions reported back in binary format or the analogue position signal is described in section 7 Position detection/visual feedback/teach functions. The analogue position signal (resolution: 0.1 mm) is available as a cyclical value/parameter.
Outputs (IO-Link master/PLC > Control unit)/ solenoid valves	Typ. continuous output: 0.6 W (per solenoid valve from 200 ms after switching on) Power reduction: Integrated via the IO-Link electronics Typ. inrush current: 38 mA or 0.9 W/200 ms (per solenoid valve) Typ. holding current: 25 mA or 0.6 W at 24 Vdc (per solenoid valve) Operating mode: Continuous operation (100% duty cycle)
Safety position in the event of a bus error/ breakdown*	If the bus fails, the solenoid valves are switched to a programmable safety position (default: solenoid valves without power). Further setting options can be viewed in the IODD description. A bus error or breakdown is displayed via the top LED.

* Internal safety position:

If internal faults are detected by the device, or if the power supply of the solenoid valves cannot be ensured, for example due to (massively) exceeding or falling short of the permitted power supply, the "internal safety position" of the solenoid valves is approached (i.e. all solenoid valves off) as long as the fault persists.

3.6 IO-Link specification

IO-LINK SPECIFICATION	
IO-Link specification	V1.1.2
SIO mode	no
Vendor ID	0x0743 (= 1859) Bardiani Valvole Spa
Device ID	Port Class A: 0xBADA01 (12245505) Port Class B: 0xBADB01 (12245761)
IODD file (separately for Port Class A or B)	Download from https://ioddfinder.io-link.com
Transmission speed	230.4 kbit/s
PD input bits	48
PD output bits	8
Operate M-sequence type	TYPE_2_V (M-sequence capability: 0x0D)
Min. cycle time	5 ms
Data storage	yes
Max. line length	20 m each between IO-Link master and IO-Link device



To ensure unambiguous communication, IO-Link devices should NOT BE CONFIGURED SIMULTANEOUSLY using the global controller (PLC) via the IO-Link master and using the Bürkert Communicator (via the service interface).

3.6.1. Notes on IO-Link master configuration

The "Port cycle time" ("Scan time") for the Giotto Teach control unit must be set to "Automatic" or "As fast as possible" or to a time value in range 5..16ms (recommended 5..8ms)

3.7 Electrical data – AS-i

ELECTRICAL DATA – AS-INTERFACE	
Power supply of control unit	29.5 ... 31.6 Vdc according to specifications
Electrical connections	M12 plug (5-pin) See also section 3.12 Details on electrical connections (IO-Link, AS-i, 24 Vdc)
Current consumption*	Maximum: smaller than 160 mA In normal operation according to current reduction: smaller than 150 mA (i.e. 3 valves enabled, 1 position reported back with top LED display, no external sensor)
Current consumption top LED	approx. 57 mA and/or 1.74 W for AS-i power supply with 30.5 Vdc for status indicator incl. electronics assembly
Inputs (from master perspective)/ binary feedback signals	3 binary feedback signals and 1 x external sensor Obtaining the 3 binary valve positions S1 to S3 and S4 (from the external sensor or from target 2) is described in section 7 Position detection/ visual feedback/teach functions.
Outlets (from master perspective)/solenoid valves	0 to 3 solenoid valves (MS, LL, UL) Typ. switching capacity: 0.9 W (per solenoid valve, for 200 ms after switching on) Typ. continuous output: 0.6 W (per solenoid valve from 200 ms after switching on) Watchdog function: Integrated Power reduction: Integrated via AS-Interface electronics Typ. Inrush current (per solenoid valve): (per solenoid valve): 30 mA and 0.9 W/200 ms (at 30.5 Vdc AS-i voltage) Typ. Holding current (per solenoid valve): 20 mA and 0.6 W (at 30.5 Vdc AS-i voltage) Operating mode: Continuous operation (100% duty cycle)
Watchdog	If bus communication fails for more than 50 to 100 ms, the outlets are set to 0 (currentless)
Safety positions of solenoid valves in the event of a bus error/breakdown	If the Watchdog is enabled (default), behaviour is the same as with a failure of the auxiliary power, i.e. all solenoid valve outlets are set to "0" (currentless).

* If all 3 solenoid valves are simultaneously controlled via the AS-Interface, the electronics assembly will activate the valves successively with a 200 ms time delay to protect the bus from excessive currents.

3.8 AS-i specification/Bit assignments

AS-I SPECIFICATION	
AS-Interface profile	S-7.A.E
AS-Interface specification	V 3.0
I/O Configuration	7 hex (4 inputs, 4 outputs)
ID-Code	A hex
Extended ID code 1	7 hex
Extended ID code 2	E hex
AS-i address (factory setting)	0
AS-i profile	S-7.A.E (Note: configuration error if an AS-i control unit with S-7.A.F is replaced by a new S-7.A.E device in old systems)

AS-INTERFACE BIT ASSIGNMENT – FOR MIXPROOF VALVE (S4: EXTERNAL SENSOR)				
Data bit	D3	D2	D1	D0
Input	External sensor S4	Position S3	Position S2	Position S1
Output	not assigned	Solenoid valve UL*	Solenoid valve LL*	Solenoid valve MS*
Parameter bit	P3	P2	P1	P0
Output	not assigned	not assigned	not assigned	not assigned

* UL = Upper Lift / LL = Lower Lift / MS = Main Stroke

3.9 Electrical data – 24 Vdc

ELECTRICAL DATA – 24 V DC	
Power supply of control unit	18 to 28 Vdc (Residual ripple: 10%)
Electrical connections	M12 plug 5,8 or 12 pins in accordance with IEC 61076-2-101 or 7 pins connector or Threaded connection for cable gland PG11 or M20x1.5 See also section 3.12 Details on electrical connections (IO-Link, AS-i, 24 Vdc)
Current consumption (standby current)	30 mA at 24 Vdc
Current consumption top LED	approx. 43 mA and/or 1 W for power supply with 24 Vdc for status indicator incl. electronics assembly
Inputs for valve actuation (MS, LL, UL)	Signal level – active: U larger than 10 V, max. 24 Vdc + 10% Signal level – inactive: U smaller than 5 V Impedance: larger than 30 kOhm
Solenoid valve (MS, LL, UL)	Typ. switching capacity: 0.9 W (per solenoid valve, for 200 ms after switching on) Typ. continuous output: 0.6 W (per solenoid valve from 200 ms after switching on) Current consumption per solenoid valve: 50 mA at 12 Vdc 25 mA at 24 Vdc 22 mA at 28 Vdc Operating mode: Continuous operation (100% duty cycle)
Outlets/binary feedback signals	S1 to S4 Design: Normally open contact (NO – normally open), PNP outlet short circuit proof, with self-locking short circuit protection Switchable output current: Max. 100 mA per feedback signal Output voltage – active: \geq (operating voltage – 2 V) Output voltage – inactive: max. 1 V in the unloaded state

3.10 Electrical data – external (inductive) sensor

An external (inductive) sensor for position detection “UL” or S4 can be connected via the triple terminal strip on the respective electronic module (3.12 Details on electrical connections (IO-Link, AS-i, 24 Vdc)).

ELECTRICAL DATA – EXTERNAL SENSOR	
Input/proximity switch (external inductive sensor): S4IN See also section 3.12 Details on electrical connections (IO-Link, AS-i, 24 Vdc)	
Power supply	IO-Link: via the IO-Link power supply (POWER 1) – 10% AS-i: AS-Interface voltage present at device – 10% 24 Vdc: Voltage present at device – 10%
Current carrying capacity, sensor power supply:	IO-Link and AS-i: Max. 30 mA 24 Vdc: Max. 90 mA
Short-circuit protection	available
Design	DC 2-wire and 3-wire, normally open contact (NO) or normally closed contact (NC) Factory settings: IO-Link: Normally open contact AS-i and 24 Vdc: Normally open contact, PNP outlet
Input current 1 signal	I(Sensor) larger than 6.5 mA, limited internally to 10 mA
Input voltage 1 signal	U(Sensor) larger than 10 V
Input current 0 signal	I(Sensor) smaller than 4 mA
Input voltage 0 signal	U(Sensor) smaller than 5 V

3.11 Position detection data

TECHNICAL DATA FOR POSITION DETECTION	
Target for main stroke	
Target description	Magnetic target (for thread connections M12 or M16) for contactless detection of max. 3 teach positions S1, S2, S3 (see section 7.1 Position detection)
Stroke range/resolution	0 to 75 mm/resolution: 0.1 mm
Feedback fields for S1, S2, S3 * (factory settings)	upper/positive: +1.5 mm (setting range: +0.5 to +10.0 mm)* lower/negative: -1.5 mm (setting range: -0.5 to -10.0 mm)*
External sensor for position S4 (optional)	
Power supply	24 V dc
Ambient temperature	-10 to +70 °C
See also sections: 3.10 Electrical data – external (inductive) sensor and 3.12 Details on electrical connections (IO-Link, AS-i, 24 V dc) and 5 Installation of the Giotto Top (Installation of the external inductive sensor)	

* The feedback fields S1 to S3 can be set using the Bürkert Communicator (bus stick).
The setting for the feedback fields S1 to S3 is also possible via IO-Link.

In the event of any doubt, please contact Bardiani Valvole S.p.A.

3.12 Details on electrical connections (IO-Link, AS-i, 24 Vdc)

IO-Link Port Class A (electronic module and plug)

<p>Solenoid valve connections with status LED for MS, LL, UL</p> <p>Terminal strip for external sensor</p> <p>Teach keys T1, T2, T3</p>		<p>Service interface</p> <p>Connections power 1, IO-Link</p>	
			<p>Pin 1: L+ 24 Vdc</p> <p>Pin 2: Not assigned</p> <p>Pin 3: L- 0 V (GND)</p> <p>Pin 4: C/Q IO-Link</p>

IO-Link Port Class B (electronic module and plug)

<p>Solenoid valve connections with status LED for MS, LL, UL</p> <p>Terminal strip for external sensor</p> <p>Teach keys T1, T2, T3</p>		<p>Service interface</p> <p>Connections Power 2</p> <p>Connections power 1, IO-Link</p>	
			<p>Pin 1: L+ 24 Vdc (Power 1)</p> <p>Pin 2: 2L+ 24 Vdc (Power 2)</p> <p>Pin 3: L- 0 V (GND - Power 1)</p> <p>Pin 4: C/Q IO-Link</p> <p>Pin 5: 2M 0 V (GND - Power 2)</p> <p>(Power 1 - power supply for the system)</p> <p>Power 2 - Power supply for actuators/solenoid valves)</p>

IO-Link - power supply of POWER 1/POWER 2:

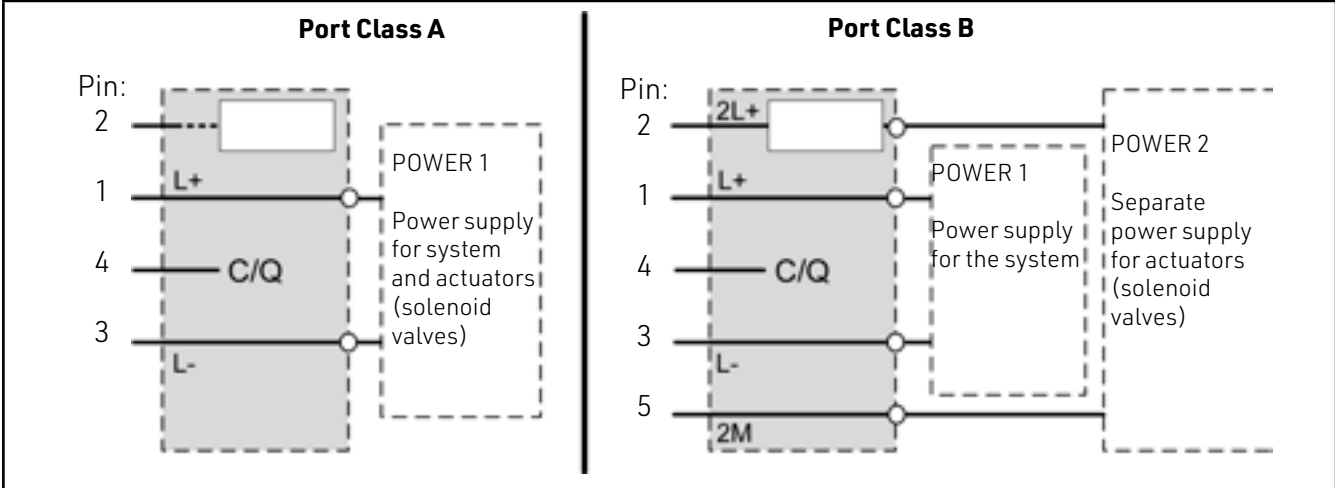

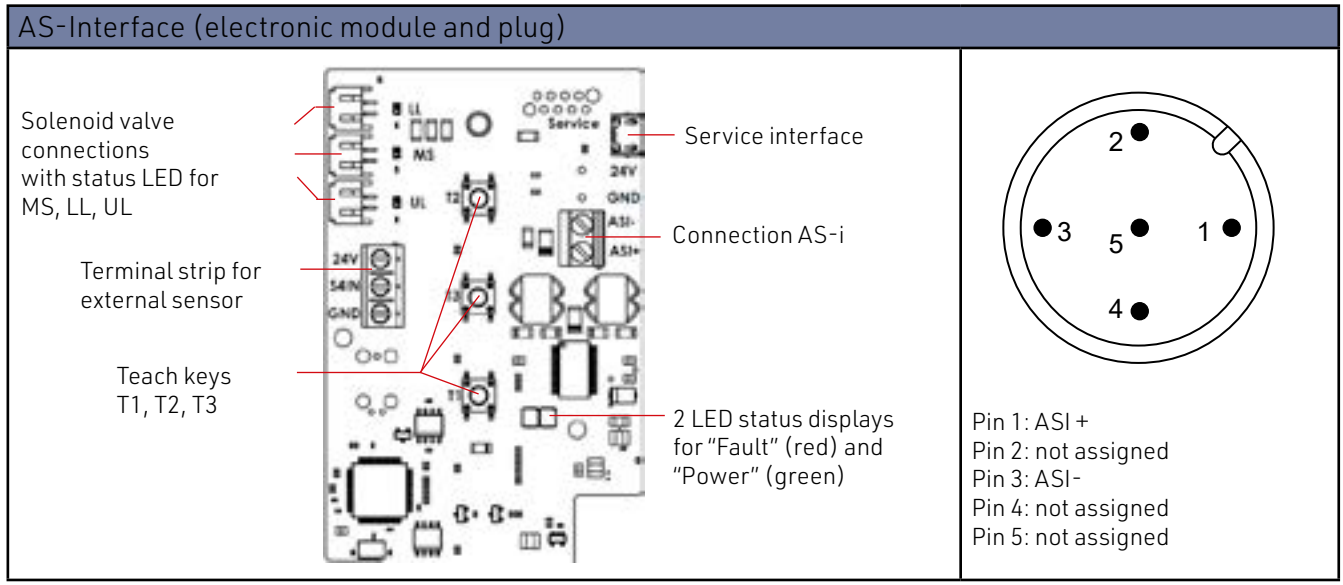

24 Vdc (electronic module and plugs)

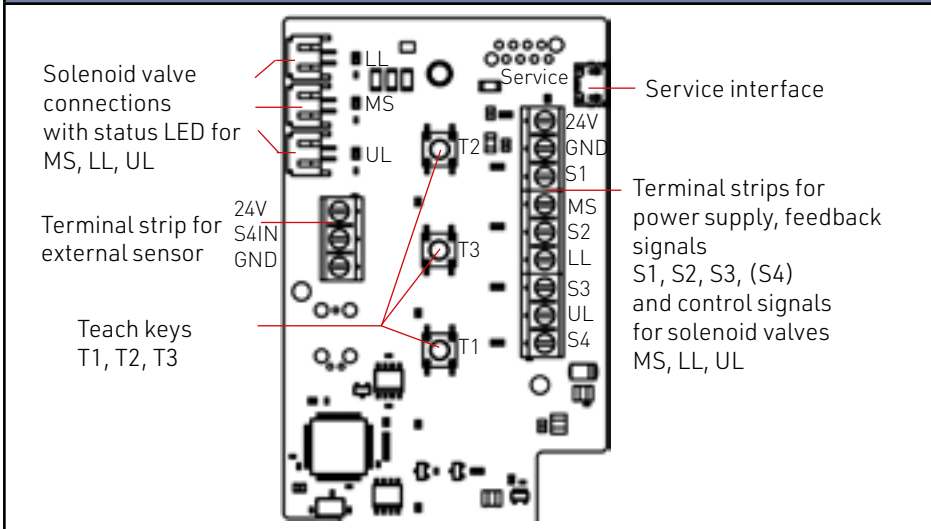

Terminal strip 9-fold:

24 V : Power supply
 GND : GND
 S1 : Outlet position S1
 MS : Solenoid valve MS input
 S2 : Outlet position S2
 LL : Solenoid valve LL input
 S3 : Outlet position S3
 UL : Solenoid valve UL input
 S4 : Outlet position S4

Pin assignment of the 7-pin connector

Pin 1:	LL	Solenoid valve LL input
Pin 2:	UL	Solenoid valve UL input
Pin 3:	MS	Solenoid valve MS input
Pin 4:	GND	GND (0 V)
Pin 5:	24 V	Power supply 24 Vdc
Pin 6:	S2 (out)	Outlet position S2
Pin 7:	S1 (out)	Outlet position S1

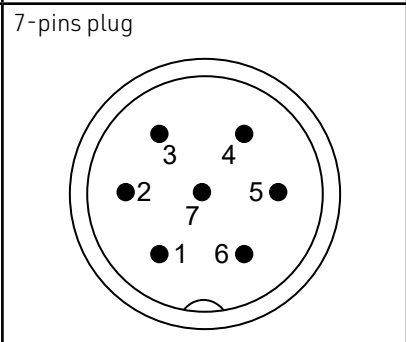

Pin assignment of the 5-pins connector (according to IEC 61076-2-101)

Pin 1:	24 V	Power supply 24 Vdc
Pin 2:	S1 (out)	Outlet position S1
Pin 3:	GND	GND (0 V)
Pin 4:	S2 (out)	Outlet position S2
Pin 5:	MS	Solenoid valve MS input

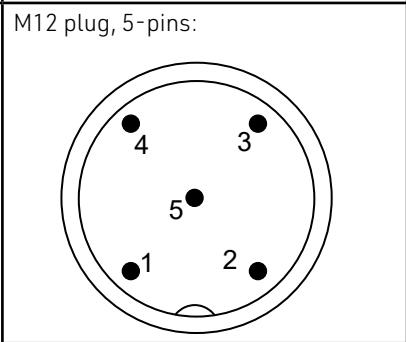

Pin assignment of the 8-pins connector (according to IEC 61076-2-101)

Pin 1:	S1	Outlet position S1
Pin 2:	24 V	Power supply 24 Vdc
Pin 3:	UL	Solenoid valve UL input
Pin 4:	LL	Solenoid valve LL input
Pin 5:	MS	Solenoid valve MS input
Pin 6:	S2	Outlet position S2
Pin 7:	GND	GND (0 V)
Pin 8:	S3	Outlet position S3

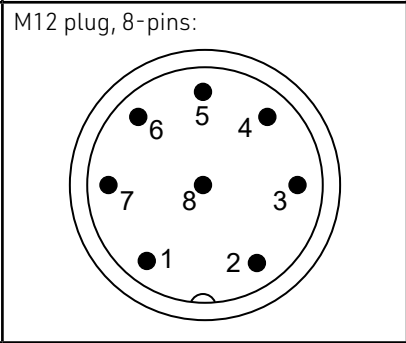

24 Vdc (electronic module and plugs)																															
<p>Pin assignment of the M12 connector (according to IEC 61076-2-101)</p> <table border="0"> <tr> <td>Pin1:</td> <td>24 V</td> <td>Power supply 24 Vdc</td> </tr> <tr> <td>Pin 2:</td> <td>GND</td> <td>GND (0 V)</td> </tr> <tr> <td>Pin 3:</td> <td>S1</td> <td>Outlet position S1</td> </tr> <tr> <td>Pin 4:</td> <td>S2</td> <td>Outlet position S2</td> </tr> <tr> <td>Pin 5:</td> <td>S3</td> <td>Outlet position S3</td> </tr> <tr> <td>Pin 6:</td> <td>S4</td> <td>Outlet position S4</td> </tr> <tr> <td>Pin 7:</td> <td>MS</td> <td>Solenoid valve MS input</td> </tr> <tr> <td>Pin 8:</td> <td>UL</td> <td>Solenoid valve UL input</td> </tr> <tr> <td>Pin 9:</td> <td>LL</td> <td>Solenoid valve LL input</td> </tr> <tr> <td></td> <td>(Pin 10 to 12:</td> <td>not assigned)</td> </tr> </table>	Pin1:	24 V	Power supply 24 Vdc	Pin 2:	GND	GND (0 V)	Pin 3:	S1	Outlet position S1	Pin 4:	S2	Outlet position S2	Pin 5:	S3	Outlet position S3	Pin 6:	S4	Outlet position S4	Pin 7:	MS	Solenoid valve MS input	Pin 8:	UL	Solenoid valve UL input	Pin 9:	LL	Solenoid valve LL input		(Pin 10 to 12:	not assigned)	<p>M12 plug, 12-pins:</p>
Pin1:	24 V	Power supply 24 Vdc																													
Pin 2:	GND	GND (0 V)																													
Pin 3:	S1	Outlet position S1																													
Pin 4:	S2	Outlet position S2																													
Pin 5:	S3	Outlet position S3																													
Pin 6:	S4	Outlet position S4																													
Pin 7:	MS	Solenoid valve MS input																													
Pin 8:	UL	Solenoid valve UL input																													
Pin 9:	LL	Solenoid valve LL input																													
	(Pin 10 to 12:	not assigned)																													

Connection of an external inductive sensor to detect position S4:								
<p>Connection of DC 2 wires:</p>	<p>Connection of DC 3 wires:</p>	<p>Connections:</p> <table border="0"> <tr> <td>"24 V"</td> <td>Power supply</td> </tr> <tr> <td>"S4IN"</td> <td>Input external sensor</td> </tr> <tr> <td>"GND"</td> <td>GND external sensor</td> </tr> </table>	"24 V"	Power supply	"S4IN"	Input external sensor	"GND"	GND external sensor
"24 V"	Power supply							
"S4IN"	Input external sensor							
"GND"	GND external sensor							
<p>The wire cross-sections of the external sensor must be between 0.14 and 1.5 mm².</p> <p>See also sections: 3.10 Electrical data - external (inductive) sensor 3.11 Position detection data 5 Installation of the Giotto Top Teach (Installation of the external inductive sensor)</p>								

Double acting	
<p>Solenoid valve connection MS</p> <p>Electronic module (section)</p>	<p>Brief description: One solenoid valve NO and one solenoid valve NC are controlled together via output "MS" - see schematic diagram on the left.</p> <p>This connection can be used for all versions of electronic modules.</p>

4 Checking / Unpacking / Lifting

1. CHECK:

- Make sure the control unit shows no signs of damage caused during transport and that it corresponds with the order;



2. PACKING DISPOSAL:

The control unit packaging is made up of cardboard, wood and plastic.

The control unit is primarily made from plastic materials. The gaskets are usually made from elastomers.

Disposal must be in compliance with local legislation.



3. VALVE LIFTING:

Exercise caution when lifting the control unit.



WARNING!

Before lifting, make sure there are no disassembled or separate parts which could fall off causing injury to persons and damage to the valve.



4. WAREHOUSING:

Avoid storing the control unit in a damp, dusty, wet or excessively hot place. Avoid areas subjected to strong vibrations.

The permitted storage temperature is between -10° and +25°C.

5 Installation of the Giotto Top Teach

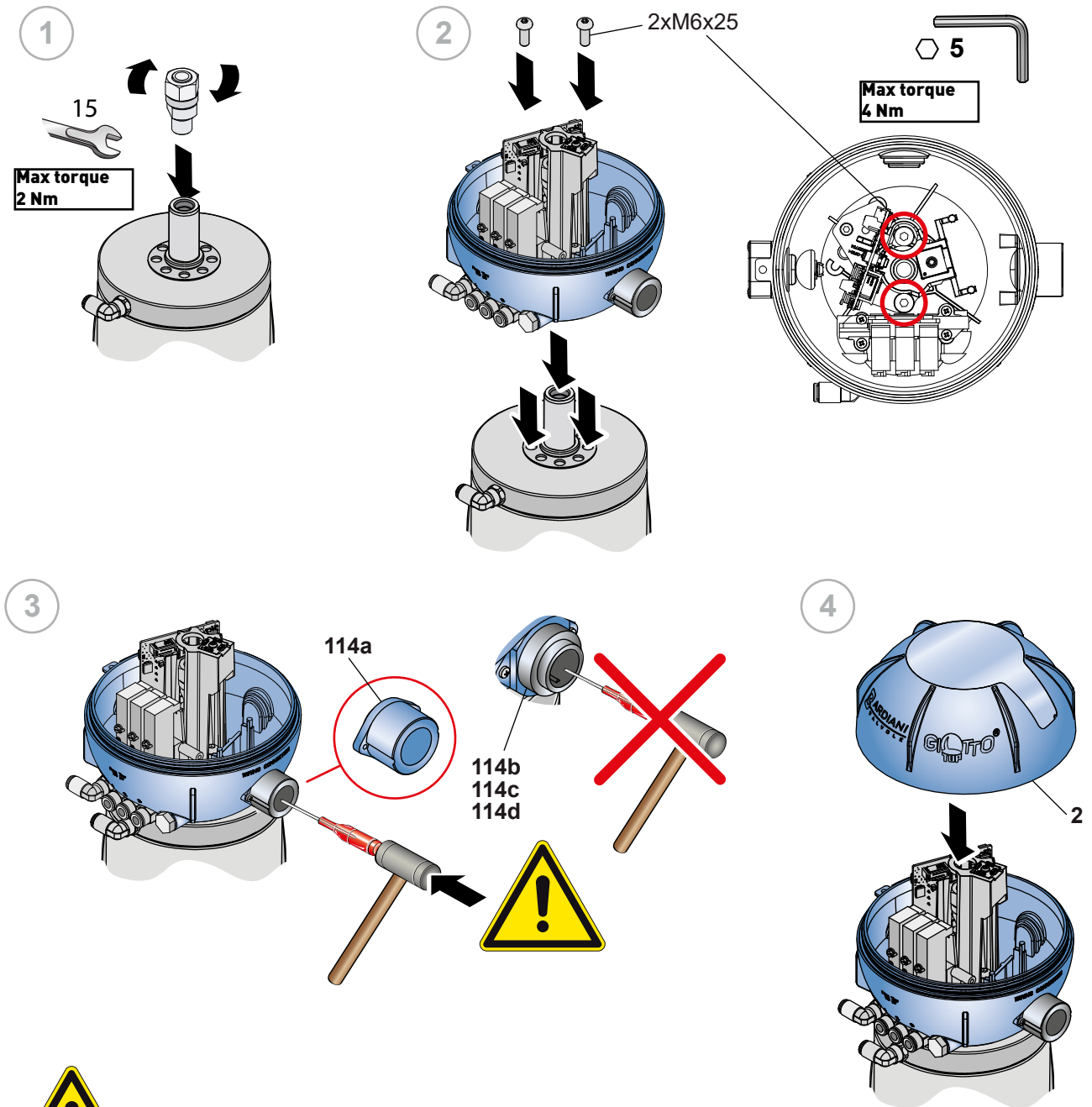

WARNING

Always make sure that all wires are correctly connected and that all parts are installed and securely fastened in the Giotto Top Teach control unit.



WARNING

Always make sure that the electrical and pneumatic connections are not enabled when carrying out operations on the Giotto Top Teach.

5.1 External inductive sensor installation

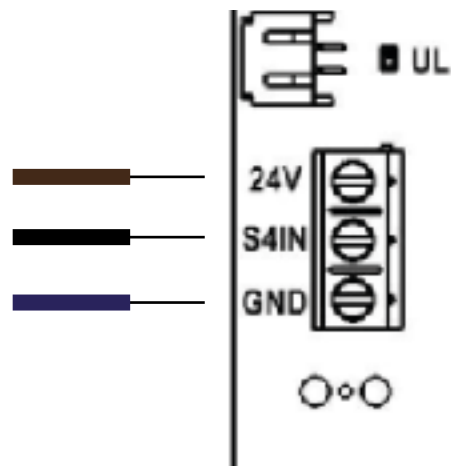
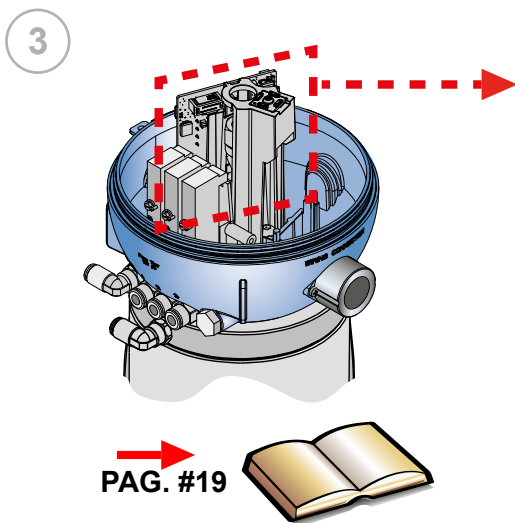
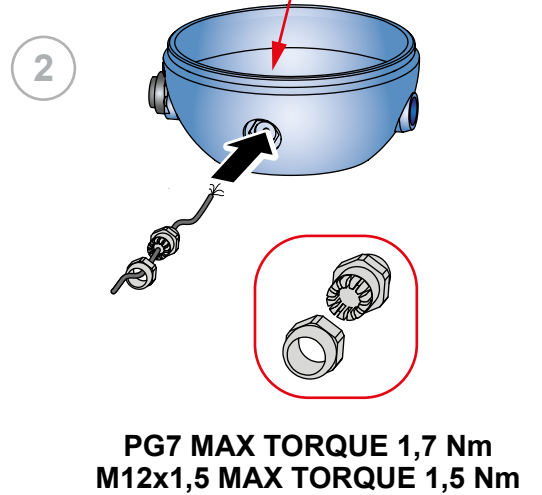
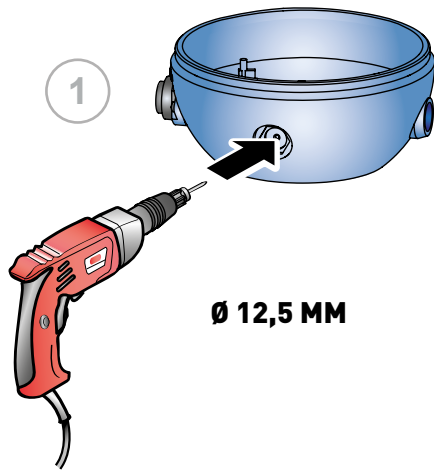

For proper installation of the external inductive sensor, please refer to the installation use and maintenance manual of the valve where the sensor is being installed

6 Giotto Top Teach pneumatic connections

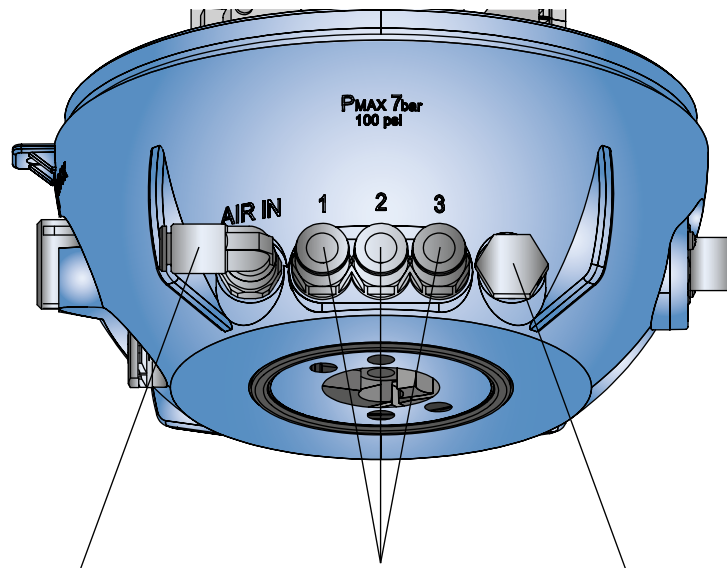
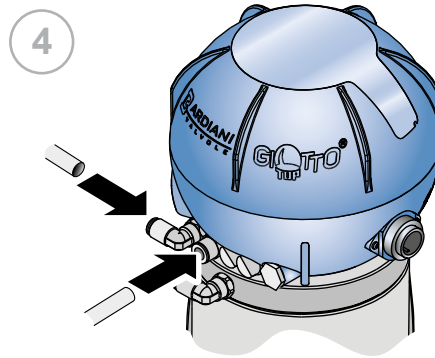

Compressed Air Inlet. Use hose with an external diameter of 6 mm. A 1/4" air fitting can be supplied upon request.

Air connections to pneumatic actuator
Use only hose with an external diameter of 6 mm

Air vent



WARNING

Only use hose lines with diameter compatible with the size of the air fitting.

Single acting actuator

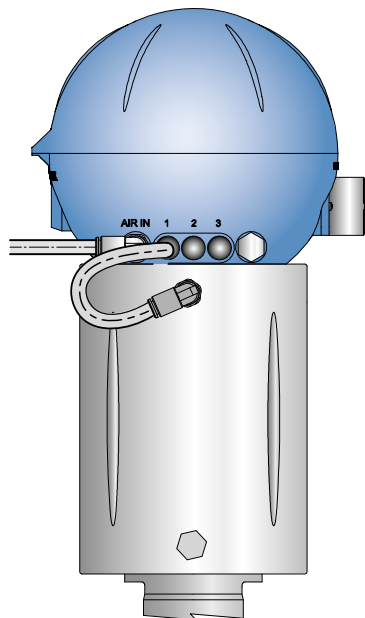

BBZP - BBYP - BBWP

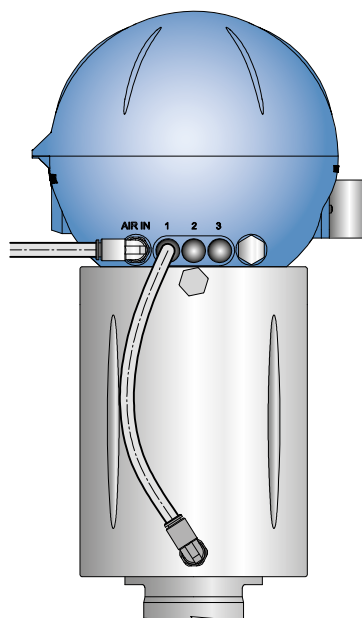

BBZP - BBYP - BBWP

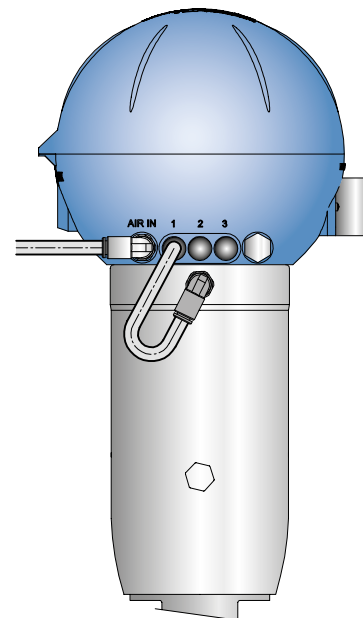

ZVF

Double acting actuator

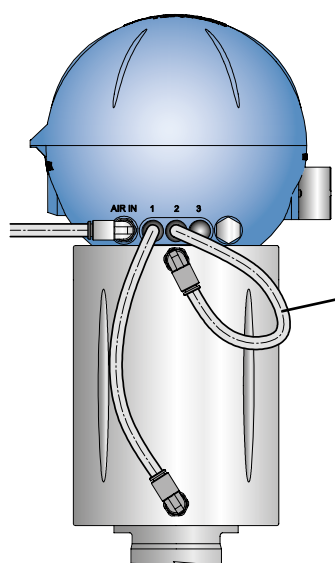

**BBZP - BBYP -
BBZQ**

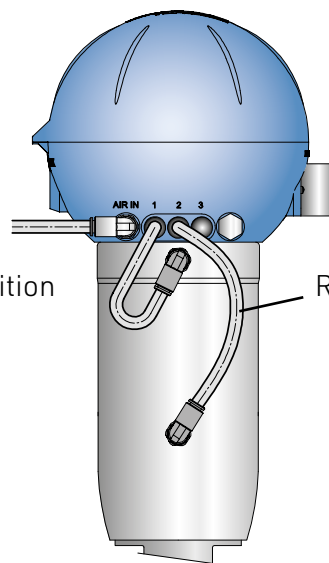

ZVF

Single acting actuator with Twin Stop actuator

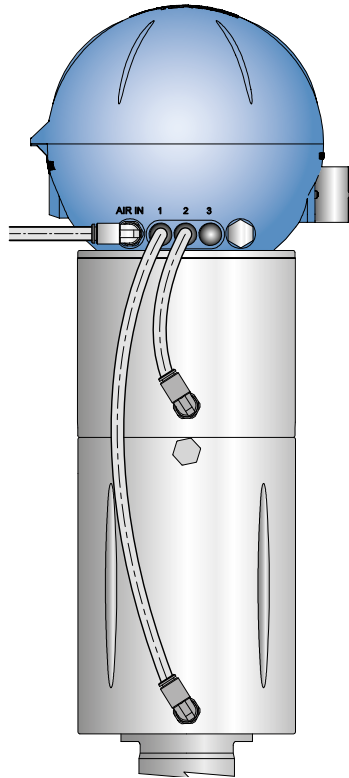

Double acting actuator with Twin Stop actuator

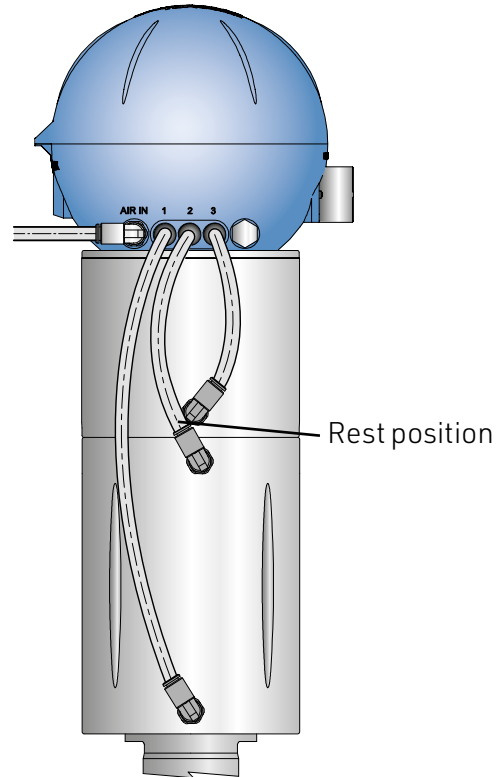

Double seat mixproof valve actuator

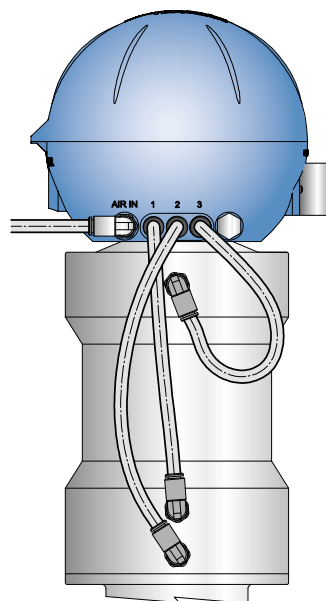

Double seal mixproof valve actuator

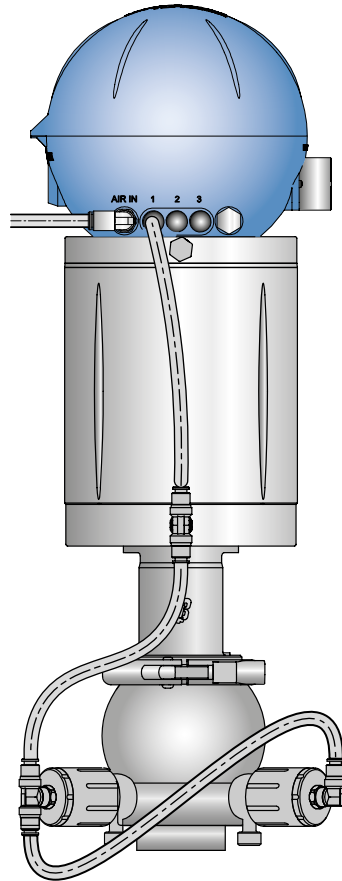

6.1 Manual override of the solenoid valves in the control unit

If compressed air is present, the process valve can be switched pneumatically using up to three solenoid valves located in the control unit. Each one has a manual override that can be used to open or close the solenoid valve (after removing the cap of the control unit) to control the process valve. See also section 6 Giotto Top Teach Pneumatic connections.

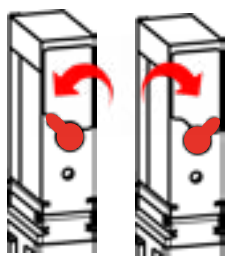
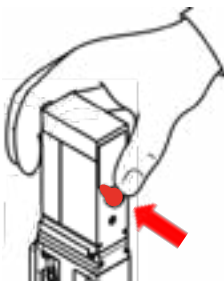
<p>Turn (90°):</p>  <p>Rest position (OFF) Activated position (ON)</p>	<p>Press like in the picture</p> 	<p>Manual override: * press OR turn the red hand lever: (Do NOT turn and press at the same time, otherwise the solenoid valve may be damaged!)</p> <ul style="list-style-type: none"> • Turn: turning by 90° permanently enables / disables the solenoid valve. • Press: the solenoid valve is enabled when the hand lever is pressed (recommendation: pressing like in the picture reduces the application of force!)
---	---	--

* Solenoid valve Type 6510 C (NC): Pushing OR turning the hand lever possible, solenoid valve Type 6510 D (NO): only turning the hand lever possible



Notes

- If the solenoid valve is actuated via controller technology, it cannot be switched by manual override.
- After the service measures have been completed, all hand levers must be reset to Rest position (OFF) in order to enable controlled operation of the system!

7 Position detection/visual feedback/teach functions

Technical data on position detection (targets, external sensor) can be found in section 3.11 Position detection data.

7.1 Position detection

Position detection – with magnetic target (and external sensor):

The position sensor in the control unit works with a magnetic target (for threaded connection M12 or M16). The position sensor thus detects the valve states “closed”, “open” and, in the case of double-seat valves, the “lower seat lift enabled” (teach positions S1 to S3).

The “upper seat lift enabled” signal of a double-seat valve can be detected by an external sensor connected to the S4IN connection (position S4).

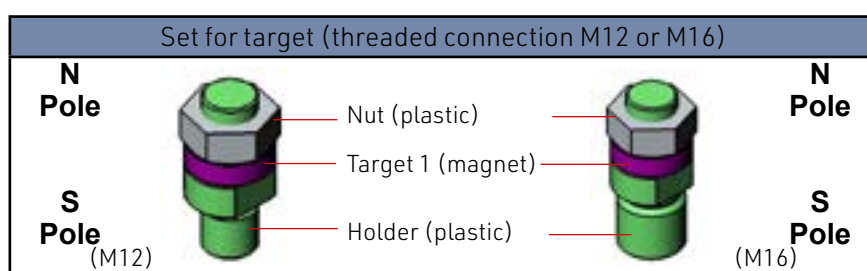

The position of the target and their measurement ranges are shown in the sketch below:

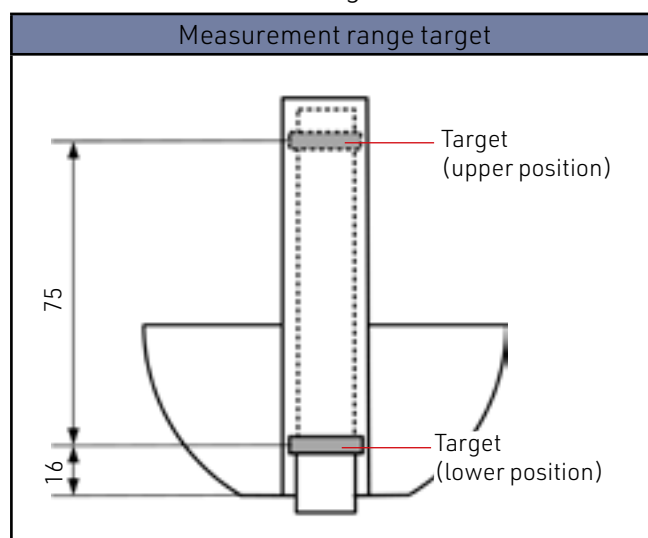

Visual feedback of the positions S1 to S3 and position S4 is provided via the top LED – see the following section 7.2 Visual feedback (top LED)

External sensor for position detection S4

An external (inductive) sensor for position detection “UL” or S4 can be connected via the triple terminal strip on the respective electronic module.

See also sections:

3.10 Electrical data – external (inductive) sensor,

3.11 Position detection data

3.12 Details on electrical connections (IO-Link, AS-i, 24 Vdc)

and for installation:

5 Installation of the Giotto Top (installation of external inductive sensor)

7.2 Visual feedback (top LED)

The following visual feedback signals are given via the top LED according to the position signal combinations S1 to S3 (S4) for the process valve states:

FEEDBACK SIGNALS FOR TOP LED DISPLAY (STANDARD)						
Position signal \ Top LED Colour*	Process valve "closed" yellow*		Process valve "open" green*	Mixproof valve (Lift strokes) white*		
		Mixproof valve type "PMO"			Mixproof valve type "PMO"	
S1	1	0	0	1	0	0
S2	0	0	1	0	0	0
S3	0	1	0	0	1	0
S4	0	1	0	1	0	1

* These colours for visual feedback are factory settings.
The lift strokes – upper and lower lift – are always displayed in the same colour.

The factory setting of the colours can be changed using the Bürkert Communicator or via IO-Link (see the IODD or the separate IODD description).

The top LED is **OFF** (factory setting) for:

- intermediate positions that are not "taught"
- the detection of position signal combinations that are not included in the table above

Signal combinations S1–S3/S4 depending on process valve type

Depending on the use of an additional sensor (external) to detect position S4 ("UL"/upper lift stroke), these position signal combinations (S1 to S4) are displayed as follows via the top LED for the various process valve types:

MIXPROOF VALVE – WITHOUT EXTERNAL SENSOR (POSITIONS S1 TO S3)		
Position of process valve	Colour of top LED	Feedback signal for position
closed	yellow	S1
open	Green	S2
Upper lift stroke	yellow	S1
Lower lift stroke	white	S3

MIXPROOF VALVE – WITH EXTERNAL SENSOR (POSITIONS S1 TO S4)		
Position of process valve	Colour of top LED	Feedback signal for position
closed	yellow	S1
open	Green	S2
Upper lift stroke	white	S1 + S4
Lower lift stroke	white	S3

MIXPROOF VALVE TYPE "PMO" WITH EXTERNAL SENSOR (POSITION S2 TO S4)		
Position of process valve	Colour of top LED	Feedback signal for position
closed	yellow	S3 + S4
open	Green	S2
Upper lift stroke	white	S3
Lower lift stroke	white	S4





NAMUR display for device status and warnings/errors:

In addition to the teach positions, the device status – based on NAMUR – can also be displayed:

0.5 s OFF + 0.5 s device status as double flashing in status colour + **0.5 s OFF**.

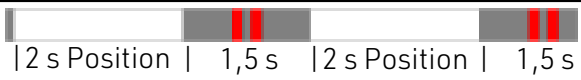
Position and device status (according to NAMUR) can be displayed alternately (continuously alternating) via the top LED. The basic pattern is:

2 s position indicator and **1.5 s device status LED** etc. (see table below)

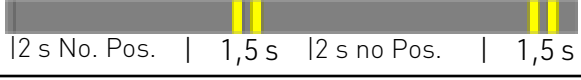
NAMUR STATUS INDICATOR		
Device status according to NAMUR	Colour(s)	Display diagram
Error	Position: in accordance with position/ "NAMUR": red	 2 s Position 1,5 s 2 s Position 1,5 s
Functional test	Position: in accordance with position/ "NAMUR": orange	 2 s Position 1,5 s 2 s Position 1,5 s
Warning	Position: in accordance with position/ "NAMUR": yellow	 2 s Position 1,5 s 2 s Position 1,5 s
Maintenance/maintenance required	Position: in accordance with position/ "NAMUR": blue	 2 s Position 1,5 s 2 s Position 1,5 s
no position detected + teach function required	Position: none (LED OFF)/ "NAMUR": yellow	 2 s No. Pos. 1,5 s 2 s no Pos. 1,5 s

Signal priorities

If several NAMUR device statuses overlap, the highest-ranking message is displayed as a priority:

1. Red: Error
2. Orange: Functional test
3. Yellow: Warning/out of specification
4. Blue: Maintenance message/need

7.3 Manual teach functions (MTF)

MTF – Overview/visual feedback top LED:

Each individual position (S1 to S4) can be taught separately by hand.

To do this, the process valve must be moved to the desired position (e.g. by manually overriding the solenoid valves – see section 6.1 Manual override of the solenoid valves in the control head) and this position is then taught using the corresponding teach key T1 to T3 on the electronic module (hold down for at least 2.5 s to max. 5 s, then release).

The selection time, the start and the progress of the respective teaching process can be seen from the changing LED signal. Position or position colour and NAMUR device status display corresponds to the factory settings according to section 7.2 Visual feedback (top LED).

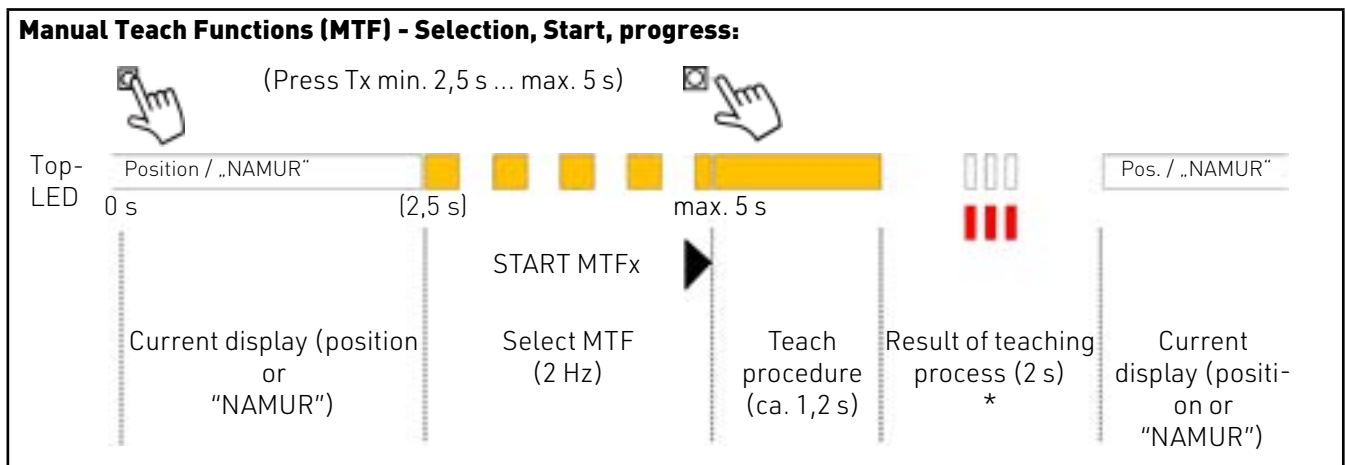

* 3 flashes to confirm the taught position in position color (yellow, green, white) or Indicates an error (3 flashes in red)

The steps required for manual teaching for the various process valves are listed below. The detailed descriptions ATF1 to ATF4 in section 7.4 Automatic teach functions (ATF) provide information on the procedure.

MTF FOR NC OR NO VALVES		
MTF for position	Teach key	Duration of operation
For NC valves, first close the process valve and teach S1, then open the process valve and teach S2 (corresponds to ATF1). For NO valves, first open the process valve and teach S2, then close the process valve and teach S1 (corresponds to ATF2).		
S1	T1	min. 2.5 s to max. 5 s (process valve: “closed” position)
S2	T2	min. 2.5 s to max. 5 s (process valve: “open” position)

MTF FOR MIXPROOF VALVES WITHOUT EXTERNAL SENSOR

MTF for position	Teach key	Duration of operation
The procedure corresponds to ATF3 (see detailed description ATF3). (An external sensor is not used here.)		
S1	T1	min. 2.5 s to max. 5 s (process valve: "closed" position)
S2	T2	min. 2.5 s to max. 5 s (process valve: "open" position)
S3	T3	min. 2.5 s to max. 5 s (process valve: "lower lift enabled")

MTF FOR MIXPROOF VALVES WITH EXTERNAL SENSOR

MTF for position	Teach key	Duration of operation
(S4)	The procedure corresponds to ATF3 (see detailed description ATF3). The external sensor for detecting S4 must first be manually set to "Upper lift enabled". Then teach the following positions manually:	
S1	T1	min. 2.5 s to max. 5 s (process valve: "closed" position)
S2	T2	min. 2.5 s to max. 5 s (process valve: "open" position)
S3	T3	min. 2.5 s to max. 5 s (process valve: "lower lift enabled")

MTF FOR PM0 MIXPROOF VALVES WITH EXTERNAL SENSOR

MTF for position	Teach key	Duration of operation
(S4)	The procedure corresponds to ATF4 (see detailed description ATF4). For PM0/mixproof valve with external sensor, S4 is recorded via the external sensor as signal S4IN; set this external sensor to "closed" manually beforehand! Consequently, only teach S3 and S2 afterwards.	
S3	T3	min. 2.5 s to max. 5 s (process valve: "closed" position)
S2	T2	min. 2.5 s to max. 5 s (process valve: "open" position)

7.4 Automatic teach functions (ATF)

ATF – Overview/visual feedback top LED:

The teach procedure for the valve positions S1 to S3 can be simplified by the automatic teach function ATF1 to ATF4. The ATF to be applied must be selected in accordance with the process valve type and intended purpose. It can be started using teach keys or, with IO-Link, using a higher-level controller:

ATFx/process valve	Teach key	Duration of operation	Comments
ATF1/valve NC	T1	min. 5 s to max. 10 s	
ATF2/valve NO	T2	min. 5 s to max. 10 s	
ATF3/Mixproof valve	T3	min. 5 s to max. 10 s	
ATF4/ PMO Mixproof valve*	T1+T3 (simultaneous)	min. 5 s to max. 10 s	external sensor required

* When the ATF4 teach function is started, the S4IN signal is automatically checked in the closed position. The external inductive sensor is connected and supplies a high signal for S4IN.

Note:

The selection time, the start and the progress of the teaching process can be seen from changing LED signal:

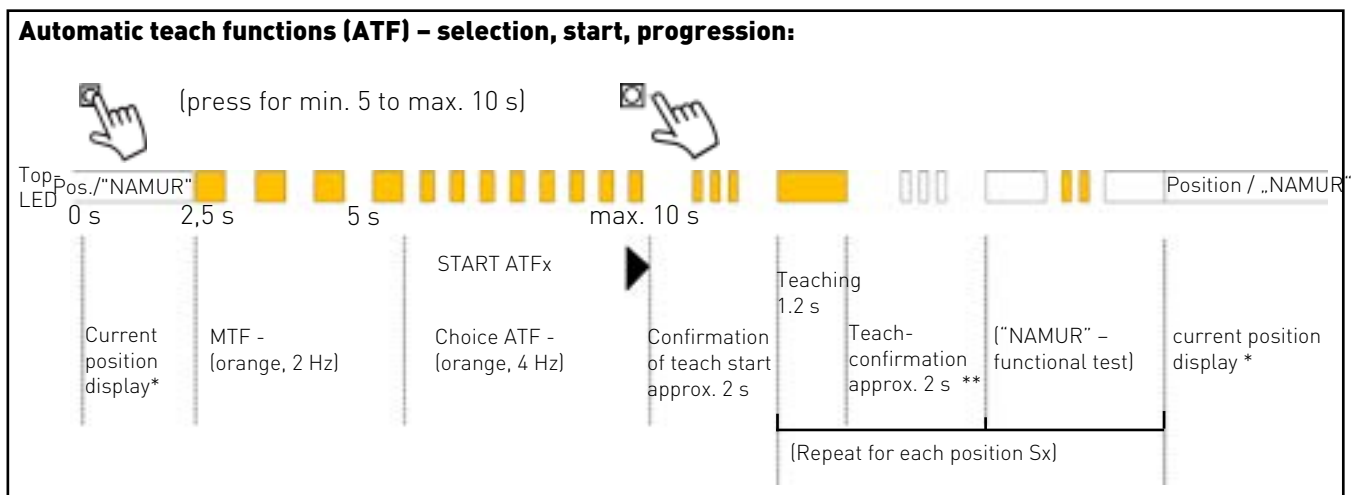

* Display of the current position in position color (yellow, green, white) or "NAMUR" device status display

** 3 flashes to confirm the taught position in position color (yellow, green, white) or Indicates an error (3 flashes in red)

General information on the ATF:

Starting conditions:

- ATF start only possible if no solenoid valve is controlled from the PLC/Bürkert Communicator

Termination conditions:

- Valve is controlled by PLC/Bürkert Communicator during ATF

Behaviour on ATF termination:

- Device status goes to error "Teach function failed", corresponding event is sent for IO-Link

For IO-Link devices, after the positions have been saved, the valve positions are started up again to record the opening/closing times as part of the teach function.

Detailed description of ATF1:

ATF1 is used for the automatic teaching of normally closed valves (NC).

	Activation (5 s to 10 s)	Effect on the process valve	Internal program	Error
1		Process valve (PV) in teach position S1 (move into)	(S1 – closed)	
2	T1	ATF1 starts		
3		Teach reset	Message to controller technology: "no position"	
4		Inspection	for "no movement"*	
5		Closed position	Teach S1	
6		Open process valve	Enable MS	Timeout 15 s
7		Inspection	for "no movement"*	
8		Open position	Teach S2	
9		Close process valve	Disable MS	
10		Process valve closes	Wait on position S1	Timeout 15 s
11		End of ATF1		
12	With IO-Link devices: After the positions have been saved, the valve positions are started up again to record the opening/closing times as part of the teach function.			
	Taught positions fed back to controller technology during ATF: - 24 Vdc devices: via SxOUT outputs - AS-i devices via input data bits - IO-Link devices via cyclical process data			

* "No movement" means: movement of less than 1 mm in 2 s

Exemplary explanations of the ATF1 process:

1. Check starting conditions: solenoid valves are not actuated, process valve is normally in mechanical safety position – here: closed position (close if necessary!)
2. ATF1 is started by activating and releasing teach key T1 for between 5 and 10 s.
The display via the top LED is as shown in the figure for ATF.
3. ATF1 starts with teach reset and "no position" feedback to controller technology
4. Check that no process valve movement is taking place for 2 s; feedback: "no position"
5. Teach Position S1 (process valve "closed"), feedback to controller technology: Position S1
6. Enable solenoid valve MS to open the process valve (timeout 15 s)
7. Check that no process valve movement is taking place (2 s long)
8. Teach Position S2 (process valve "open"), feedback to controller technology: Position S2
9. Disable solenoid valve MS to close the process valve (timeout 15 s)
10. Check if Position S1 has been reached again, feedback to controller technology: Position S1
11. End of ATF1, change to normal operating mode and display of current position
12. For IO-Link devices, run through all positions again to check the times

Detailed description of ATF2:

ATF2 is used for the automatic teaching of normally open valves (NO).

	Activation (5 s .. 10 s)	Effect on the process valve	Internal program	Error
1		Process valve (PV) in teach position S2 (move into)	(S2 - open loop)	
2	T2	ATF2 starts		
3		Teach reset	Message to controller technology: "no position"	
4		Inspection	for "no movement"*	
5		Open position	Teach S2	
6		Close process valve	Enable MS	Timeout 15 s
7		Inspection	for "no movement"*	
8		Closed position	Teach S1	
9		Open process valve	Disable MS	
10		Process valve opens	Wait on position S2	Timeout 15 s
11		End of ATF2		
12	With IO-Link devices: After the positions have been saved, the valve positions are started up again to record the opening/closing times as part of the teach function.			
	Taught positions fed back to controller technology during ATF: <ul style="list-style-type: none"> - 24 Vdc devices: via SxOUT outputs - AS-i devices via input data bits - IO-Link devices via cyclical process data 			

* "No movement" means: movement of less than 1 mm in 2 s

Detailed description of ATF3:

ATF3 is used for the automatic teaching of Mixproof process valves, with or without external sensors.

	Activation (5 s to 10 s)	Effect on the process valve	Internal program	Error
If an external sensor is used to detect S4, it should first be set to "Upper Lift Position" before the ATF3 is started.				
1		Process valve (PV) in teach position S1 (move into)	(S1 – closed)	
2	T3	ATF3 starts		
3		Teach reset	Message to controller technology: "no position"	
4		Inspection	for "no movement"*	
5		Teach position (position S1)	Teach S1	
6		Control process valve	Enable MS	Timeout 15 s
7		Inspection	for "no movement"*	
8		Position S2 of the PV	Teach S2	
9		Move PV to teach position S1	Disable MS	Timeout 15 s
10		Inspection	for "no movement"*	
11		Process valve in position S1	Wait on position S1	
12		Control process valve	Enable LL	Timeout 15 s
13		Inspection	for "no movement"*	
14		Position S3 of the PV	Teach S3	
15		Move PV to teach position S1	Disable LL	Timeout 15 s
16		Inspection	for "no movement"*	
17		PV moves to teach position S1	Wait on position S1	
18		End of ATF3		
19	With IO-Link devices: After the positions have been saved, the valve positions are started up again to record the opening/closing times as part of the teach function.			
	Taught positions fed back to controller technology during ATF: - 24 Vdc devices: via SxOUT outputs - AS-i devices via input data bits - IO-Link devices via cyclical process data			

* "No movement" means: movement of less than 1 mm in 2 s

Detailed description of ATF4:

ATF4 is used for the automatic teaching of Mixproof PMO process valves with external sensor.

Check of the external sensor:

When the ATF4 teach function is started, the S4IN signal is automatically checked in the closed position: an external inductive sensor must be connected and it must supply a high signal ("1") for S4IN at the start of ATF4.

	Activation (5 s to 10 s)	Effect on the process valve	Internal program	Error
If an external sensor is used to detect S4, it shall first be set to "Closed position" before the ATF4 is started.				
1		Process valve (PV) in the teach position S1 (move into)		
2		Manual check/adjustment of the external sensor connected to S4IN so that it reports back the closed position with feedback signal 1		
3	T1+T3	ATF4 starts		
4		Teach reset	Message to controller technology: "no position"	
5		Detection recording S4	Signal S4IN must be 1 when the valve is closed	
6		Inspection	for "no movement"*	
7		Closed position	Teach S3	
8		Inspection	Position S3 and S4 active	
9		Control process valve	Enable MS	Timeout 15 s
10		Inspection	for "no movement"*	
11		Position S2 of the PV	Teach S2	
12		Inspection	Position S2	
13		Move PV to teach position (position S3, S4)	Disable MS	Timeout 15 s
14		Inspection	for "no movement"*	
15		PV in Position S3, S4	wait for position S3 and S4	
16		Control process valve	Enable LL	Timeout 15 s
17		Inspection	for "no movement"*	
18		Lower lift stroke of the PV	Check S4	
19		Move PV to teach position (position S3, S4)	Disable LL	Timeout 15 s
20		Inspection	for "no movement"*	
21		PV in Position S3, S4	wait for position S3 and S4	
22		Control process valve	Enable UL	Timeout 15 s
23		Inspection	for "no movement"*	
24		Upper lift stroke of the PV	Check S3	
25		Move PV to teach position (position S3, S4)	Disable UL	Timeout 15 s
26		Inspection	for "no movement"*	
27		PV in Position S3, S4	wait for position S3 and S4	
28		End of ATF4		
	With IO-Link devices: After the positions have been saved, the valve positions are started up again to record the opening/closing times as part of the teach function.			
	Taught positions fed back to controller technology during ATF: - 24 Vdc devices: via SxOUT outputs - AS-i devices via input data bits - IO-Link devices via cyclical process data			

* "No movement" means: movement of less than 1 mm in 2 s









Information on valves.

Control unit has the same behaviour when first installed on site.

Once the AS-i or IO-Link communication has been properly installed and set up and cyclical PLC communication to the control unit has been established, the control unit will display the warning "Teach function required" until at least one position has been learned (line 1 in the table below).

Position signal monitoring is enabled during the teaching process and as soon as at least one position has been successfully taught.

To simplify error analysis, the following brief flashing pattern is displayed via the top LED at the end of a teach function (see lines 2 to 5):

FOR INITIAL INSTALLATION OF PROCESS VALVES		
Line	Description	Display diagram
1	no position detected/teach function required	 2 s LED off 1,5 s 2 s LED off 1,5 s (No pos.) (No pos.)
2	MTF (manual teach function) successful	 (yellow) or  (green) or  (white)
3	ATF (automatic teach function) successful	normal position display or device status display ("NAMUR")
4	Teaching error*: invalid position signal	 (pink)
5	Error: other reason*	 (red)

* see also section 7.2 Visual feedback (top LED)

7.5 Reset functions

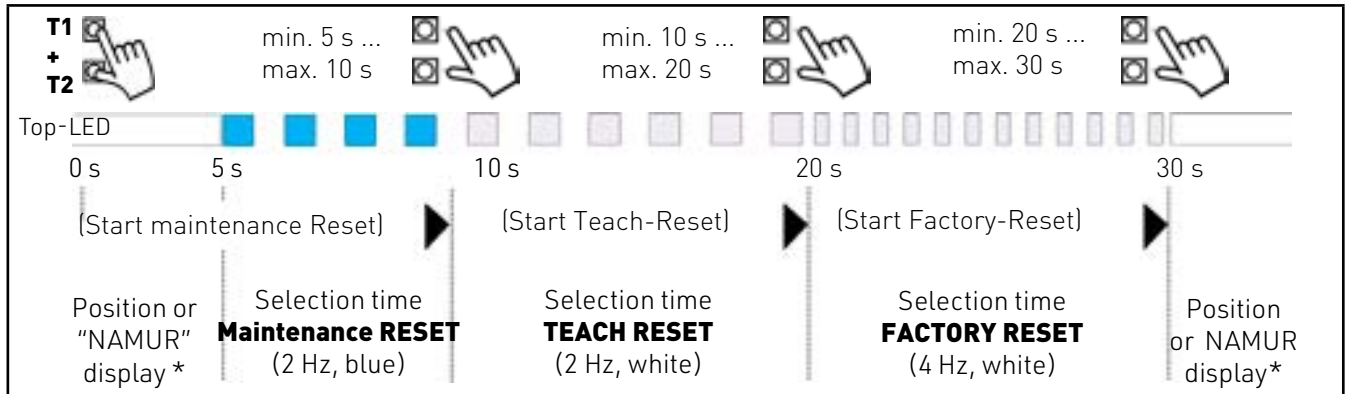

There are various reset functions that can be started by pressing the teach keys T1 and T2 simultaneously but for different lengths of time – see the following illustration:

Reset functions (selection of maintenance, teach, factory reset):



* Display of the current position in position color (yellow, green, white) or "NAMUR" device status display

Visual feedback (via top LED) and factory settings:

MAINTENANCE RESET (T1+T2 FOR 5 TO 10 SECONDS)	
Top LED display	Meaning of visual feedback
 (2 s)	3 x short flashes within 2 s in blue = confirmation, maintenance reset successfully performed
 (2 s)	3 x short flashes within 2 s in error colour (red) = maintenance reset aborted

A maintenance reset can be triggered using the teach keys (press T1 + T2 for min. 5 s to max. 10 s, then release) or using Bürkert Communicator or, with IO-Link, via the control system (IODD: Index 0x2C16).

The following values are reset to the factory settings during a maintenance reset:

- Resettable switching cycle counters for MS, LL, UL 0
- Valve stroke totaliser (cumulative): 0 mm

The switching cycle counter for the solenoid valve MS and the "cumulative valve stroke" have limit values which, when exceeded, can cause a maintenance required signal to be emitted. Factory setting: maintenance signalling disabled.

The factory settings can be changed via IO-Link or using the Bürkert Communicator.

The following applies to IO-Link devices:

Solenoid valve safety position in event of faulty and/or no cyclical IO-Link communication:	all solenoid valves "Off"
Service display option (IO-Link only):	Service indication display option: "On" (see separate IODD description)
External maintenance signalling:	disabled (external trigger maintenance function)
Local control lock (0x2C10):	disabled

Factory reset does not reset the following values:

Switching cycle counter total MS, LL, UL	
Switching cycle times (control times) MS, LL, UL, cumulative	
Operating hours totaliser	
Valve stroke totaliser (cumulative), total	
Operating duration	
AS-i address:	see Section 3.8 AS-i specification/Bit assignments
Only IO-Link devices:	Lock bits of object "0x000C – Device Access Lock" (see separate IODD description)

8 Error messages via top LED

Signal priorities

If several error messages overlap, the highest-ranking message is displayed first (red, orange, yellow, blue).

MAINTENANCE DISPLAYS (BLUE)		
DESCRIPTION	POSSIBLE CAUSE	TROUBLESHOOTING
Switching cycle counter solenoid valve MS limit value is exceeded	Set limit value has been exceeded.	- Check wear parts in pneumatic actuators and in product contact area - Reset totaliser with maintenance reset
Only for IO-Link devices: (External) maintenance function active	The external maintenance function has been enabled via controller technology	- Disable via control technology or - Restart the device

WARNING MESSAGES (YELLOW)		
DESCRIPTION	POSSIBLE CAUSE	TROUBLESHOOTING
Teach function required	(still) no position taught	- Execute teach function
Opening/closing time exceeded	The travel time* between the end positions is longer than the maximum travel time set. The evaluation is only performed for the control unit with a solenoid valve.	- Check compressed air supply - Check piping - If available, check external actuator supply voltage
Switching time** exceeded	Stationary end position has not been reached after set maximum switching time. The evaluation is only performed for the control unit with a solenoid valve.	

FUNCTION TEST MESSAGES (ORANGE)		
DESCRIPTION	POSSIBLE CAUSE	TROUBLESHOOTING
Automatic teach function (ATF) active	Automatic teach function (ATF) has been started on the device or via Bürkert Communicator or via controller technology (for IO-Link)	Message self-deletes at end of teach function.
Manual teach function (MTF) active	Manual teach function (MTF) has been started on the device or via Bürkert Communicator or via controller technology (for IO-Link).	Message self-deletes at end of teach function.
Test mode active	- Solenoid valves and/or - Feedback signals S1-S4, - Position signal are manually controlled/simulated via Bürkert Communicator via the service interface for test purposes	Message self-deletes after return to normal operation or when device is restarted

* Travel time

The time measurement begins when the current (taught) end position exited and ends when the new end position is entered.

** Switching time

The time measurement starts with the change of the current set point value to a new one (switch of a solenoid valve) and ends with the entry into the new end position

ERROR MESSAGES (RED)		
DESCRIPTION	POSSIBLE CAUSE	TROUBLESHOOTING
Position sensor error	Faulty position sensor signal caused by lack of target or target outside measurement range	- Check position sensor target for correct installation and magnet alignment
Teach function error	Last teach function failed since last device restart (e.g. due to no, overly slow or accidental valve movement)	- Reset teach function or execute teach reset function. - Check compressed air supply - Check piping
Undervoltage or overvoltage detected	Operating voltage too low or too high. The solenoid valves are disabled.	- Check operating voltage - Check the wiring
Electronic module initialisation error	Failed electronic module initialisation	- Exclude other causes of error - Check power supply
Persistent memory cannot be used	Non-volatile memory cannot be used	- Restart device If error still active after restart:
Voltage recording error	Error when recording operating voltage	- Contact Bardiani service
Only for AS-i devices:		
AS-i communication error	- AS-i slave address = 0 - No data traffic (expired watchdog at slave address does not equal 0) Detailed diagnostics via AS-i status LEDs on electronic module. No feedback of this error via AS-i peripheral fault.	If AS-i slave address = 0: - Address assigned by AS-i addressing device In case of no data traffic: - Check AS-i master status and configuration - Check the wiring
Only for IO-Link devices:		
IO-Link errors	Cyclical communication is interrupted or not set up yet. The solenoid valves are accessed in accordance with the configured safety position if the bus breaks down.	- Create cyclical IO-Link communication (sending a cyclical value to the device is necessary for some IO-Link masters). - Check the wiring - Check IO-Link master port cycle time settings (see 3.6.1 Notes on IO-Link master configuration)
Overvoltage actuator supply detected	Only for Port Class B devices: External voltage for actuator supply too low or too high or out of specification. The solenoid valves are disabled.	- Check voltage for actuator supply
Actuator supply voltage out of specification		- Check the wiring
Overload temperature error (overtemperature)	Device temperature too high for operation.	- Reduce ambient temperature

8.1 Troubleshooting and error messages



FAULT	CAUSE	REMEDY
Air leak at the solenoid valve holder	No seals or loose fitting	Check the seals for leaks and tighten the screws
Air leak at the safety valve		
Top LED not lit	Electronic module or electrical connection defective	Check electrical connection or replace the control unit
	LEDs defective	
	Sensor system failed	
Solenoid valve not actuated	Solenoid valve damaged	Replace solenoid valve
	Air supply pressure not correct	See section Technical data in the manual
	Solenoid valve holder damaged	Replace solenoid valve holder
	Electrical connections not made correctly	Check connections
	Manual override of the solenoid valve enabled	Set manual override to factory setting, see section 6.1 Manual override of the solenoid valves in the control unit.
External (inductive) sensor failed	External (inductive) sensor defective	Replace external (inductive) sensor
	Electrical connections not made correctly	Check the connections in the terminal strip of the electronic module and tighten the screws
	Distance between cam and external (inductive) sensor greater than 1.5 mm	Check the centring of the Giotto control head and fastening of the double guide – see section 5 Installation of the Giotto Top Teach

AS-I ELECTRONIC MODULE	LED DISPLAYS		CAUSE
AS-i electronic module with "Error" and "Power" LED status indicators (see also section 3.12 Details on electrical connections (IO-Link, AS-i, 24 V DC))	"Error" LED (red)	"Power" LED (green)	Signalised status
	off	off	Power OFF, no voltage present
	off	on	OK/in operation
	on	on	No data traffic (expired Watchdog at slave address does not equal 0)
	on	Flashes	Slave address = 0
(The "Error" signal is also displayed via the top LED)	Flashes	Flashes	Sensor supply overload and "peripheral fault": <ul style="list-style-type: none"> • Electronic module error (hardware) • Operating voltage outside tolerance • Sensor failure or target outside measuring range • Teach function error

9 Cleaning



Always make sure that the electrical and pneumatic connections are disconnected when carrying out operations on the control unit.



1. PRECAUTIONS

The system in which the control unit is installed must be cleaned by expert personnel in observance of the following:

- Use only non-abrasive and non-aggressive detergents compatible with the materials which make up the control unit.
- Observe the instructions provided by the detergent suppliers and adhere to the recommended concentrations.
- Always wear protective safety glasses and gloves.



2. CLEANING

If detergents or cleaning agents containing acids or alkaline substances are used, always make sure the control unit is rinsed immediately with clean water.

Never direct high-pressure jets of water at the control unit.

Pay particular attention to those areas where there are orifices or openings.

10 Disposal



At the end of its service life, the device must be recycled in accordance with the legislation in force in the country of valve use.

Any hazardous residues must be taken into consideration and adequately handled.

The control unit is made up of: elastomers (gaskets), plastic (control unit) and electrical components (terminal board, solenoid valves, sensors).

Before disconnecting the control head and process valve, observe the following steps with reference to section 11 Maintenance:

- Ensure that the line in which the control head is installed is not in operation
- Disconnect air supply
- Disconnect electrical supply
- Remove the control head from the valve
- For detailed information on removing the control head, see section 11.2 Assembly / disassembly instruction of the Giotto Top Teach

11 Maintenance



1. PRECAUTIONARY MEASURES

If used correctly, the control unit does not require any special maintenance.

Any repairs must be carried out by specialist personnel; always disconnect the power and compressed air supply before working on the control unit.



WARNING

Risk of injury from electrical voltage and high pressure!

Always make sure that the electrical and compressed air connections are disconnected when interventions are carried out on the control unit.



2. REPLACEMENT OF WEARING PARTS

If it is necessary to replace any part of the control unit, it is essential to order an original spare part from Bardiani Valvole S.p.A., as the use of a third-party product may jeopardise correct operation and endanger personnel.



WARNING

Risk of damage to the inside parts of the control unit!

Each time you close the cap, make sure that the position of the cables inside does not hinder the movement of the cam with the target.



3. SPARE PARTS:

Consult the spare parts manual to determine the part to be replaced.

For information and spare parts enquiries, please contact our service department:

Email: service@bardiani.com

Tel: +390525400044

11.1 Components description

NO.	DESCRIPTION
21	Base
21a	Sealing ring
21b	Sealing ring
21d	Double guide
21e	Vent plug
21f	Air coupling
21g	Air coupling
21i	Cap
21k	Terminal block with support
22	Cam
25	Screw
26	Bardiani case
27a	Sensor
27d	Micro-size inductive sensors holder slide
114a	Sleeve for cable gland
114b	7-pole connector
114c	5-pole connector
114d	8-pole connector
192	Solenoid valve
192b	Solenoid valve support
192c	Cap
192d	Solenoid valve gasket
192e	Sealing ring

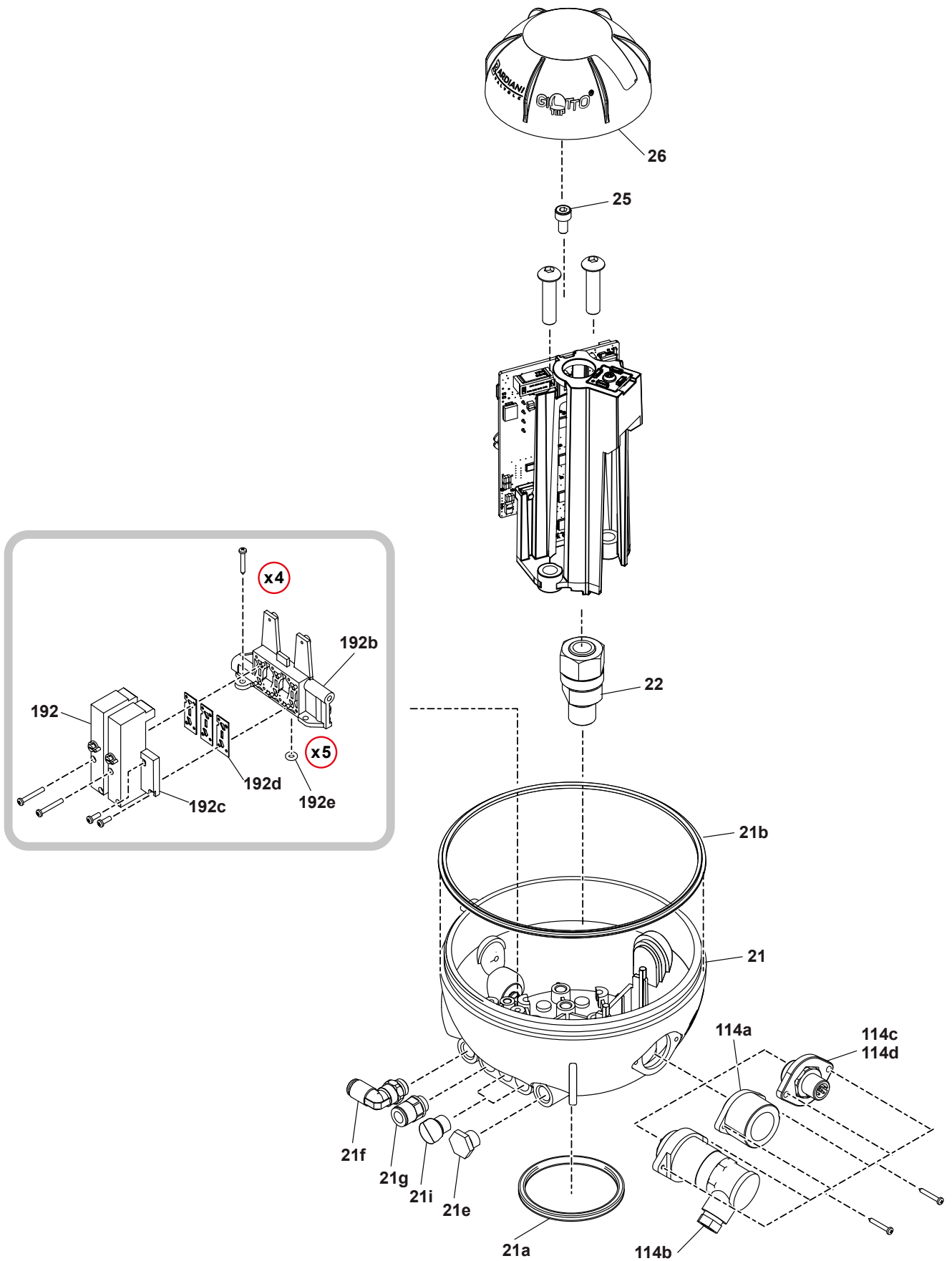

11.2 Assembly/ disassembly instruction of the Giotto Top Teach

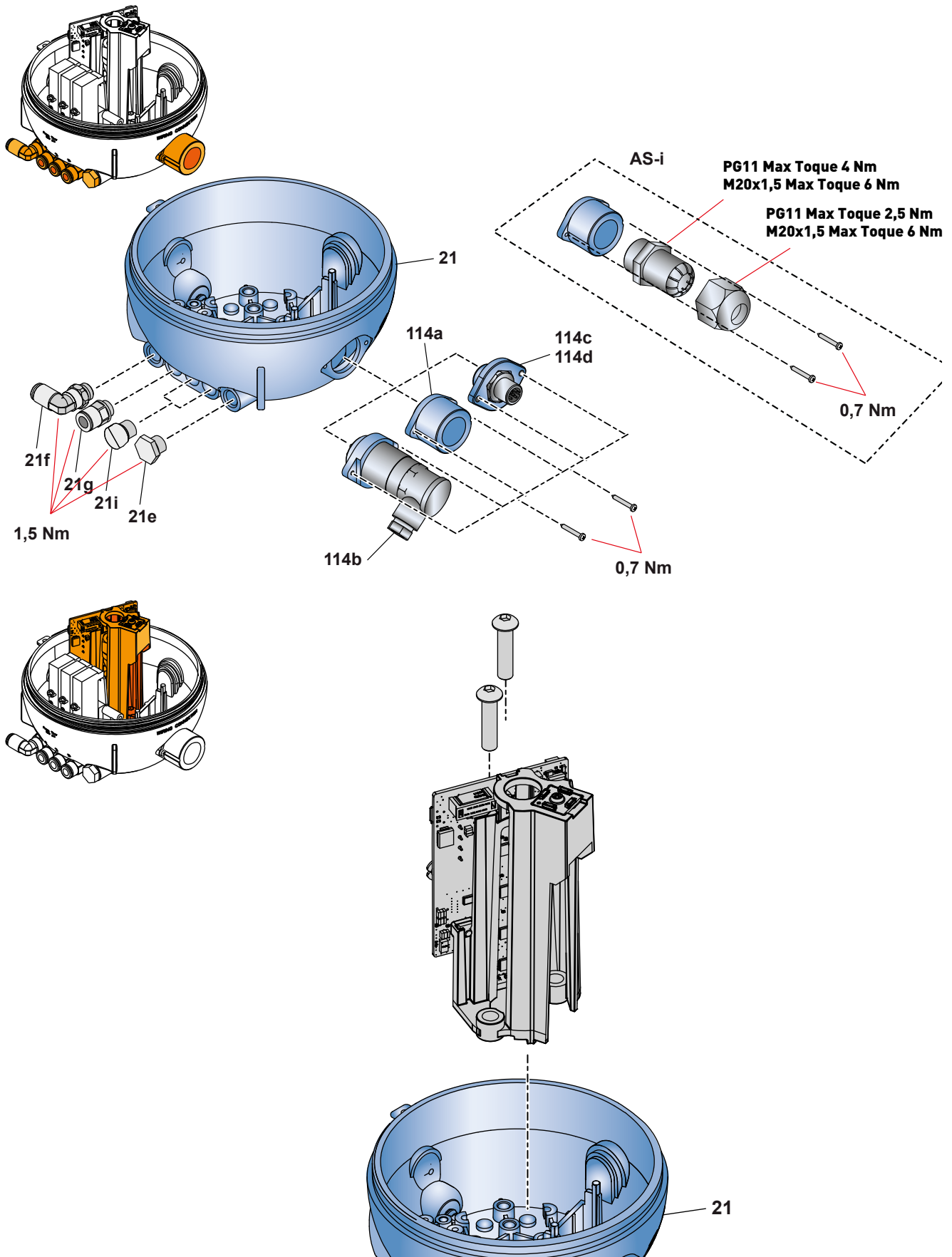

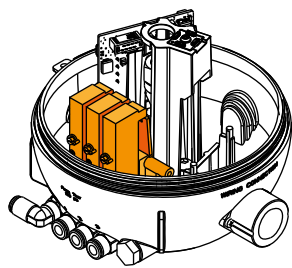

TYPE B

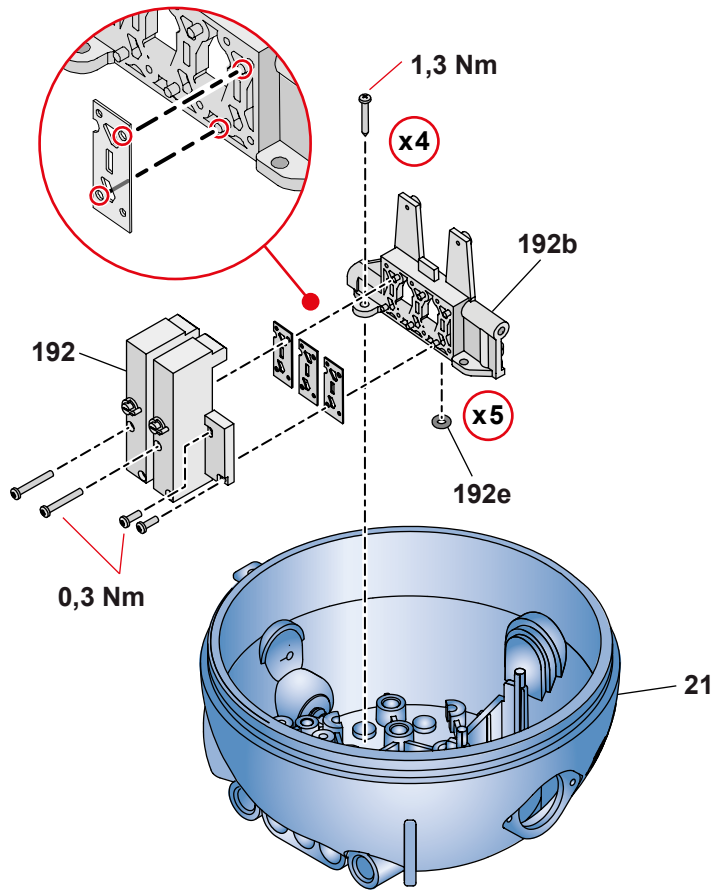

Solenoid valve sequence

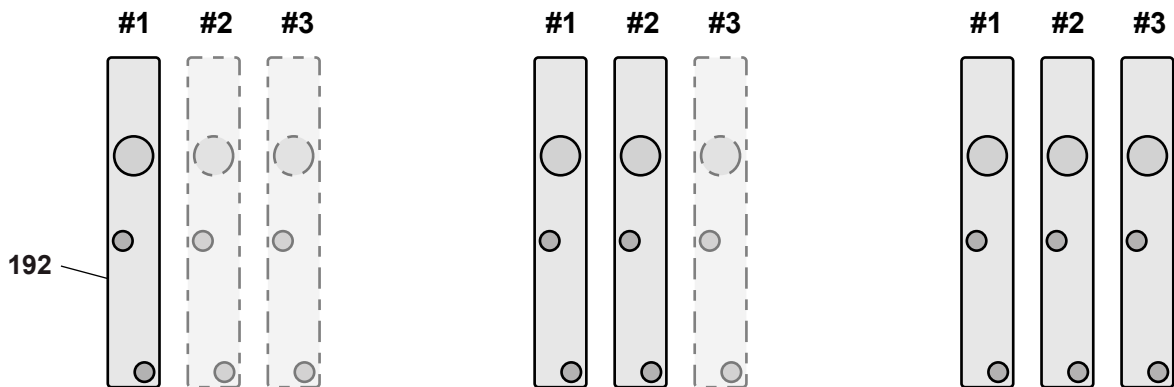

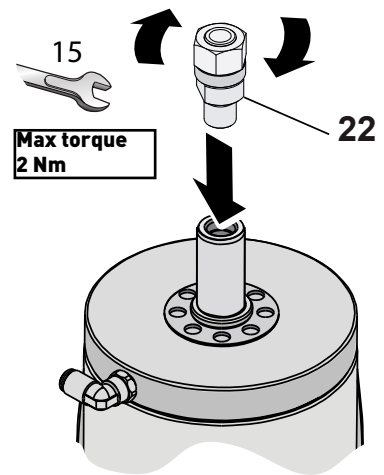
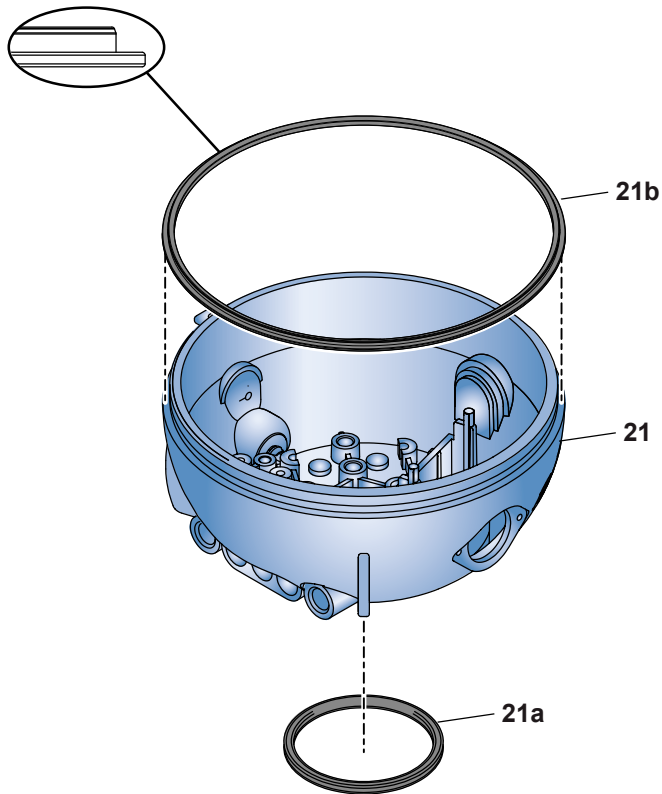

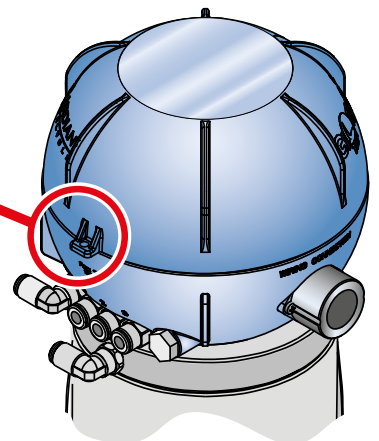
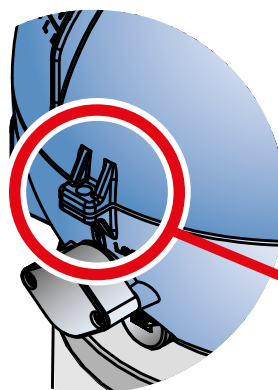
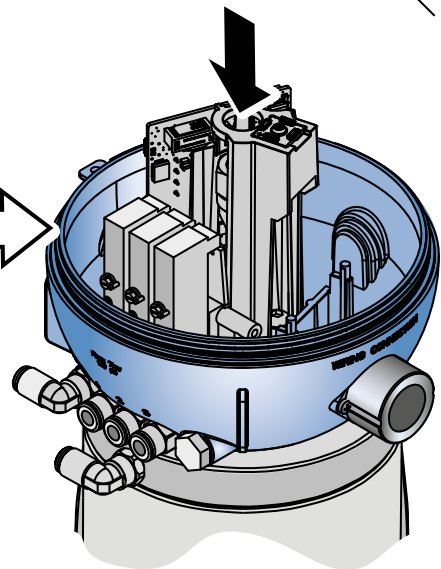
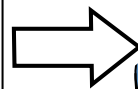
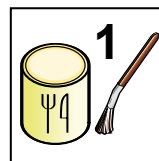
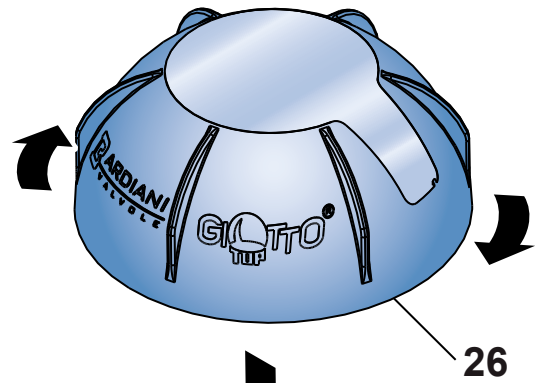
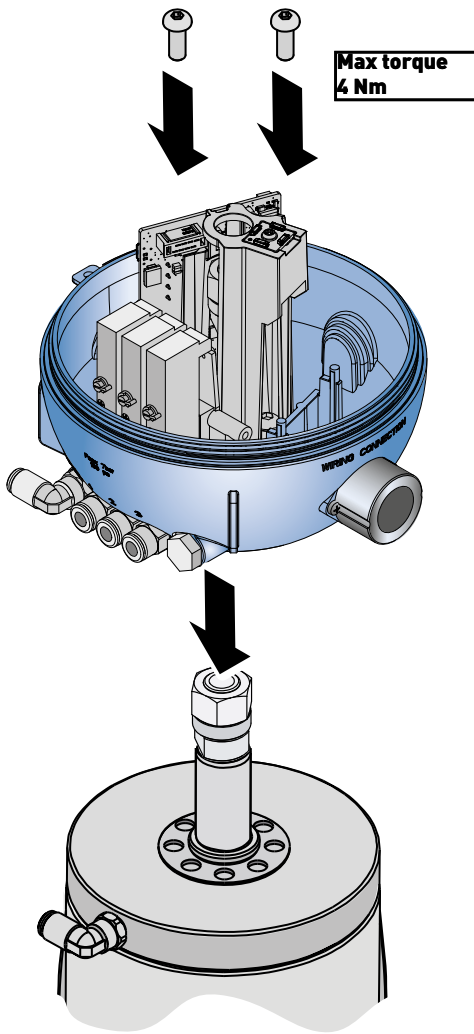

12 Warranty

1. VALIDITY

Bardiani Valvole's Products are manufactured in compliance with the technical specifications laid out in their "Instruction, Use and Maintenance Manual" and are fully compliant with the directives specifically mentioned in these manuals.

Bardiani Valvole S.p.A. guarantees its own products against any design and/or construction and/or material defects and/or faults for a period of 12 (twelve) months from the date of delivery.

Notification of any Product defects and/or faults must be sent in writing to Bardiani Valvole S.p.A. within 8 (eight) days from their detection, providing adequate documentation of the defect/fault encountered as evidence.

Services provided in the warranty period shall not result in an extension of the warranty beyond the stipulated 12 (twelve) month period, as this warranty validity period is to be considered mandatory.

2. CONTENTS OF THE WARRANTY

Notwithstanding and without prejudice to the rights of the Buyer, which may be acknowledged by applicable law, this warranty is to be intended as limited, at the discretion of Bardiani Valvole S.p.A., to the repair and/or replacement of the Product and/or part of the Product and/or its components which is/are found to be defective due to design and/or manufacturing and/or material faults.

- In the event of repair and/or replacement of the Product and/or any one of its parts and/or components, any returned item/s shall become the property of Bardiani Valvole S.p.A. and the relative shipping costs shall be at the expense of Bardiani Valvole S.p.A.
- Bardiani Valvole S.p.A., shall be under no obligation to compensate for any immaterial and/or indirect damages and shall in no way be held liable for consequential damages and/or losses, such as (by way of example only), damages due to loss of business, contracts, opportunities, time, production, profits, goodwill, image etc..
- No retailer or distributor or dealer or agent or representative or employee or person appointed by Bardiani Valvole S.p.A. is authorized to make any amendments and/or integrations and/or extensions to this warranty.

3. EXCLUSIONS FROM THE WARRANTY

Elastomers are expressly excluded from this warranty.

This warranty does not cover design faults emerging whenever a Product is manufactured by Bardiani Valvole S.p.A. based on designs and/or technical specifications provided by the Buyer.

Application of this warranty also excludes:

- faults and/or defects resulting from incorrect and/or unsuitable and/or improper transport for the Product,
- faults and/or defects resulting from installation of the Product which fails to observe the indications provided in the "Instruction, Use and Maintenance Manual" or in any case caused by incorrect and/or unsuitable and/or improper installation,
- faults and/or defects resulting from use and/or maintenance operations and/or storage of the Products which fail to observe the prescriptions provided in the "Instruction, Use and Maintenance Manual" or in any case which are incorrect and/or unsuitable and/or improper;
- faults and/or defects in the Product and/or its parts and/or its components;
- faults and/or defects in the Product and/or its parts and/or its components for work and/or repairs being carried out by unskilled staff or staff that has not been authorised by Bardiani Valvole S.p.A.;
- faults and/or defects in the Product and/or its parts and/or its components due to it/them being dropped and/or banged and/or dented and/or misused and/or tampering and/or breakage and/or accidents or in any event due to negligence and/or carelessness and/or neglect by the Buyer and in general for any causes not attributable to design and/or manufacturing and/or material defects;
- faults and/or defects in the Product and/or its parts and/or its components caused by other events outside the control of Bardiani Valvole S.p.A. or determined by force majeure or mishap.

13 Recommendations

- 1.** Consultation of the "Instruction, Use and Maintenance Manual" is mandatory prior to the installation, use and maintenance of all Products. All the information, indications, specifications, technical details provided herein are based on test data which the Manufacturer Bardiani Valvole S.p.A. holds to be reliable nevertheless the above is not deemed to be assumed as fully exhaustive inasmuch as not every possible use has been envisaged.
- 2.** All the illustrations and drawings provided are to be intended as indicative and therefore not binding, the illustrations being for presentation purposes only.
- 3.** Being as the conditions of Product use and applications cannot be controlled by Bardiani Valvole S.p.A., the Purchaser must ascertain suitability of the use he intends to make of the products beforehand and assume all risks and liabilities which may result from the same.
- 4.** Customer is strongly advised to consult Bardiani Valvole S.p.A.'s technical-commercial collaborators to request any specific information concerning the technical characteristics of the Products.
- 5.** The information provided in this manual refers to the standard products manufactured by Bardiani Valvole S.p.A. and therefore cannot be assumed to apply to customized products as well.
- 6.** Bardiani Valvole S.p.A. reserves the right to amend and/or integrate and/or update the data and/or information and/or technical details relative to products at any time and without prior notice. Please visit the website, www.bardiani.com, where the latest updated of the "Instruction, Use and Maintenance Manual" can be found".
- 7.** The content and validity of the warranty covering Bardiani Valvole S.p.A products are dealt with in the relative section in the "Instruction, Use and Maintenance Manual" which constitutes an integral part of the products themselves.
- 8.** The content and validity of the warranty covering the Products of Bardiani Valvole S.p.A are dealt with in the relevant section in the "Instruction, Use and Maintenance Manual" which constitutes an integral part of the Products themselves.

NOTES

NOTES

Bardiani Valvole S.p.A.
via G. di Vittorio, 50/52 - 43045 Fornovo di Taro (PR) - Italy
tel. +39 0525 400044 - fax +39 0525 3408
bardiani@bardiani.com - www.bardiani.com