

MANUAL BUTTERFLY VALVES

INSTALLATION - USE - MAINTENANCE

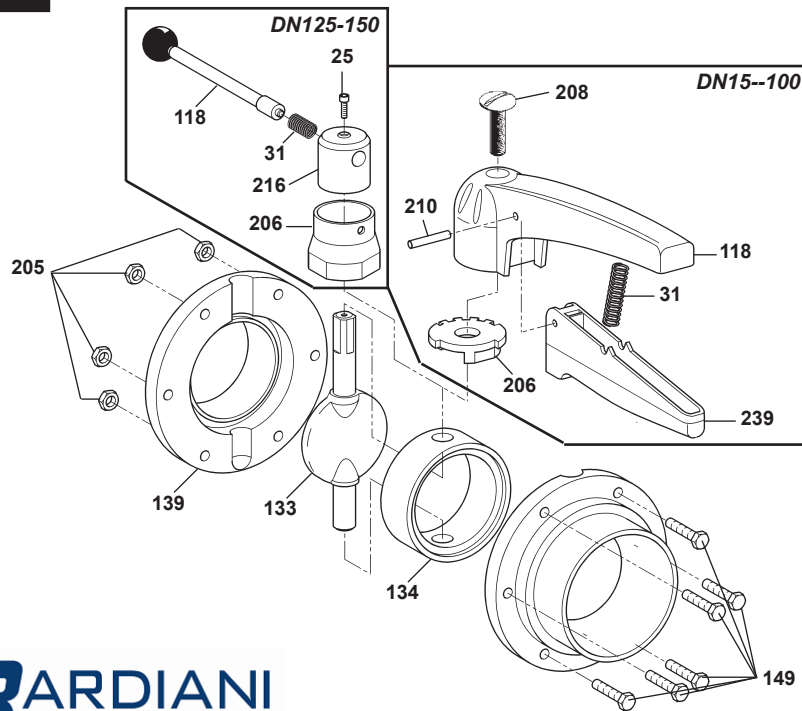

VVF



BARDIANI
VALVOLE

GB-IST-VVF-0210

Pos.	Denomination	Quantity	Material
25	BOLT		
31	SPRING		
118	HANDLE		
133	BUTTERFLY VALVE		
134	GASKET		
139	CASING		
149	BOLT		
205	NUT		
206	HANDLE POSIT. COLLAR		
208	BOLT		
210	PARALLEL PIN		
216	HUB		

GENERAL WARNING

-The manual butterfly valve model "VVF" not being safety valves cannot be used for the interception of explosive substances, inflammables, toxic or combustible products.

-They must be used within the specified pressure ratings for this type of valve.

-Read carefully the enclosed manual before installing, use and maintenance of the said valve

-Operators who come into contact with the valves must wear the appropriate protective clothing including gloves and safety glasses.

-The installation of the valve must be carried out exclusively by specialised personnel following the instructions in the manual on installation and maintenance.

-Should there be a delay for a certain period of time from when the valve was purchased to the installation of the valve, keep the valve covered in a place out of harm and away from atmospheric agents until the installation.

-Do not use parts of the valve for other uses than those it was designed for.

-Make sure that all persons involved in the use of the valves have been trained and know well all the relative instructions in this manual

-Before starting the commissioning process make sure that all object, tools and various objects that could possibly disturb the operation of the valve have been removed.

-Do not permit unqualified persons to carry out maintenance and make sure that personnel involved know well the section in the manual regarding maintenance procedures.

-Always use original spare parts from "BARDIANI VALVOLE S.P.A." when replacing damaged or worn parts.

The use of spare parts made by the customer or third parties may cause irreparable damage to the installation and it's personnel.

The manual includes a full list of original spare parts.

For further information please contact The Technical Office at "BARDIANI VALVOLE S.P.A."

Machinery Directive 97/27/EEC

(valve sizes DN15--25 are not included in accordance with Article 3 paragraph 1.3:

Valves intended for gases, liquified gases, gases dissolved under pressure, vapours and those liquids whose vapour pressure at the maximum allowable temperature is greater than 0,5 bar above normal atmospheric pressure (1013 mbar) within the following limits:

- For fluids in Group 2 with a DN greater than 32.
- Valve size DN125--150 only for fluids in Group 1 or 2 - valves intended for those liquids whose vapour at the maximum allowable temperature is lower or even than 0.5 bar within the normal atmospheric pressure (1013mbar).

WARRANTY

1. CONTRACTUAL WARRANTIES AND LIABILITY

- 1.1 Bardiani Valvole S.p.A. warrant that their products are free from defects in design, material and workmanship. Bardiani Valvole S.p.A. shall be liable should any such defects be found within 12 (twelve) months from the date of delivery of the products.
- 1.2 Any claim regarding defects and/or faults found in the products shall be notified in full and in writing to Bardiani Valvole S.p.A. within 8 (eight) days from the date they were found. Adequate documentation shall be provided as evidence of said defects at the time the claim is filed.

2. LIMITATION IN LIABILITY

- 2.1 Without prejudice to any statutory right of the Buyer, Bardiani Valvole S.p.A. shall be under no liability in respect of electric components or elastomers that are part of their products.
- 2.2 The Seller shall be under no liability in respect of defects/faults specified in the following points:
 - defects and/or faults arising from failure to follow the instructions contained in the "Manual of Instruction for the Use and Maintenance of the Product" as to the use and storage of the products by the Buyer;
 - defects and/or faults arising from fair wear and tear of the products or their parts or their components;
 - defects and/or faults arising from repairs or interventions of the goods carried out by unauthorized or unqualified staff;
 - defects and/or faults arising from misuse, accidents, negligence and abnormal working conditions caused by the Buyer.

3. WARRANTY

- 3.1 Bardiani Valvole S.p.A. shall, at their discretion, repair or replace the products that are acknowledged to be defective.
- 3.2 Should repair or replacement of the product or of its components occur, the parts returned shall become the property of Bardiani Valvole S.p.A. The relevant freight costs involved in the return of the goods or their components shall be entirely met by Bardiani Valvole S.p.A.
- 3.3 Under no circumstance shall Bardiani Valvole S.p.A. be liable to indemnify immaterial or indirect damages such as damages or consequential loss, whether loss of profit, loss of business, loss of business opportunities, loss of time, loss of goodwill and damage to corporate image, etc.
- 3.4 The performance of repair or replacement under the above warranty shall not entail any extension of the warranty period of 12 (twelve months), such term being unconditional.
- 3.5 No distributor, agent or staff to Bardiani Valvole S.p.A. is entitled to make any amendment, extension or addition to the above warranty.

DISCLAIMER

1. All the statements, indications and technical data listed in this document are based on technical tests carried out by Bardiani Valvole S.p.A.. However accurate and reliable, such tests do not reflect all possible circumstances under which the products may be used.
It is therefore advisable that the Buyer should always ascertain the suitability of the product in its application. The Buyer will be entirely liable for all risks and damages incurred by said products.
Bardiani Valvole S.p.A. are not liable for any accident, loss or damage incurred, whether they be directly or indirectly caused by the use or misuse of the products.
No further guarantees other than those stated in this document shall be granted.
2. All our customers are advised to consult our technicians as well as our offices who will supply all information pertaining the technical characteristics of our products.
3. The pictures contained in this document are intended to be general representations. They are not to be intended either legally binding or detailed representations of our products.
4. The data and statements listed in this document only refer to our standard products. They do not apply in any case to any tailor-made products that might have been purchased by the customers.
5. Bardiani Valvole S.p.A. are not liable for any defects or faults resulting from the incorrect installation of their products. Such installation is to be carried out in full compliance with the instructions contained in the "Manual of Instructions for the Use and Maintenance of the Product". Bardiani Valvole S.p.A. are not liable for any defects or faults resulting from the incorrect use of their products.
6. Bardiani Valvole S.p.A. are not liable for any defects or faults resulting from the incorrect transportation and/or incorrect storage and/or incorrect maintenance of their products.
7. Bardiani Valvole S.p.A. cannot accept any liability for any faults or damages deriving from mishandling of the products and/or interventions carried out by unqualified personnel. No liability is accepted for damages caused by hits, dents, carelessness, negligence or any other any acts that cannot be considered as construction faults or faults related to the materials used in production.

